



# INSTALLATION AND OPERATING MANUAL DPC 535 PROCESS AND DIFFERENTIAL CONTROLLERS



## NOTES



# DPC535 Quick Start Operating Instructions

## DIFFERENTIAL PRESSURE CONTROL USING STRAIN GAGE TRANSDUCERS

Refer to the full manual for unpacking and mounting instructions and terminal locations.

When using the DPC535 as a differential pressure controller (DPC535-1-1-1-2-K) with 350 Ohm Strain Gage pressure transducers such as the Dynisco PT460 series, wire as follows:

NOTE: Transducers must be of the same range.

For PV1 (upstream): Connect positive signal wire (red) to terminal 32.  
Connect negative signal wire (black) to terminal 31.  
Connect Excitation - (green) to terminal 10.  
Connect Excitation + (white) to terminal 11.  
Connect Calibration 1 (blue) to terminal 10.  
Connect Calibration 2 (orange) to terminal 12.

For PV2 (downstream): Connect positive signal wire (red) to terminal 29.  
Connect the negative signal wire (black) to terminal 28.  
Connect Excitation - (green) to terminal 10.  
Connect Excitation + (white) to terminal 11.  
Connect Calibration 1 (blue) to terminal 10.  
Connect Calibration 2 (orange) to terminal 22.

Refer to the full manual for instructions on accessing the following menus:

### IN THE CONFIGURATION MENU:

Set CTR.TYPE to Standard, Set LINE.FREQ to 60, Set PV SOURCE to PV1-PV2, Set OUTPUT 2 to ALARM ON, Set OUTPUT 3 to ALARM ON, Set OUTPUT 4 to RETRANS. Set ANLG.RNG.: 4 to desired output (4-20, 0-20, 20-4, 20-0mA), Define LOOP NAME if desired.

### IN THE PV1 MENU:

Set PV1 TYPE to 0-33.3 mV, Set LOW RANGE to match low range of transducer, Set HI RANGE to match the full-scale range of transducers, Set RESTORE to manual.

### IN THE PV2 MENU:

Set PV2SETUP to same as PV1.

### IN THE CONTROL MENU:

Set ALGORITHM to On/Off, Set SOURCE to PV (differential), Set ACTION to DIRECT, Set PVBREAK to Off.

### IN THE ALARM 1 AND 2 MENUS:

Set TYPE, SOURCE and MODE (latching or non-latching) as appropriate to the process. Set Alarm 1 OUTPUT to 2. This will cause its output to be at the output 2 terminals. Set Alarm 2 OUTPUT to 3. This will cause its output to be at the output 3 terminals. Set POWER UP as desired. If set to normal, the process will be powered up in the normal mode. If there is an alarm condition, the alarm will be activated. If set to ALARM, alarms will be activated on power up. If set to delayed, alarms will be inhibited regardless of whether or not an alarm condition exists. Define MESSAGE if desired.

### IN THE RETRANS MENU:

Set the TYP:4 To PV (differential), Set LO RANGE: 4 to the desired low end of the range, Set HI RANGE: 4 to the desired high end of the range. Under most conditions, LO RANGE and HI RANGE will encompass the full span setting of the PV's.

### IN THE SPECIAL MENU:

Set the POWER UP to Manual.

# NOTES

## IN THE SECURITY MENU:

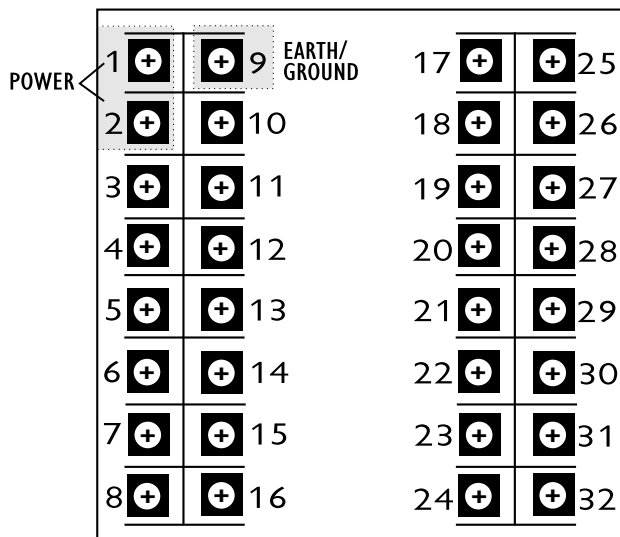
Set the appropriate Security scheme for your application.

The above setup will provide a display of the differential pressure, with its value controlling the main control output according to the operating setpoint value at terminals 3 and 4. Alarm 1 will output at terminals 5 and 6. Alarm 2 will output at terminals 7 and 8. The retransmission output will be at terminals 15 and 16.

## CALIBRATION:

Calibration is to be done with transducers at operating temperature, with no pressure applied. Return to PV1 Menu. Scroll to SHUNT. Set to 80% for Dynisco transducers. For other brands, consult the manufacturer for the correct percentage value. Set R\_CAL to yes. Set SET ZERO to PRESS ACK. Press ACK. Button. Zero calibration is finished when lower display indicates COMPLETED. SET SPAN to PRESS ACK. Press ACK. Button. Span calibration is finished when lower display indicates COMPLETED. Go to PV2 Menu. Scroll to Shunt. Repeat above procedure for PV2. Press DISPLAY button to return to operational mode. With no pressure applied, Main display should indicate 0 +/- 10 psi. Press DISPLAY button to display PV1 on lower display. It should indicate 0 +/- 10 psi. Press DISPLAY to display PV2 on lower display. It should indicate 0 +/- 10 psi.

## DPC535 TERMINAL ASSIGNMENTS - DIFFERENTIAL STRAIN GAGE INPUTS



Screws must be tight to ensure good electrical connection

TERMINAL NUMBER	TRANSDUCER 1	TRANSDUCER 2
10	Excitation - (Green) Calibration (Blue)	Excitation - (Green) Calibration (Blue)
11	Excitation + (White)	Excitation + (White)
12	Calibration (Orange)	N/A
22	N/A	Calibration (Orange)
28	N/A	Signal - (Black)
29	N/A	Signal + (Red)
31	Signal - (Black)	N/A
32	Signal + (Red)	N/A

For single Strain Gage Transducer input, wire as shown under Transducer 1 only.



## **DPC535 Quick Start Operating Instructions**

### **DIFFERENTIAL PRESSURE CONTROL USING AMPLIFIED TRANSDUCERS**

Refer to the full manual for unpacking and mounting instructions and terminal locations.

When using the DPC535 as a differential pressure controller (DPC535-1-1-1-5) with amplified pressure transducers such as the Dynisco PT4624, wire as follows:

For PV1 (upstream): Connect positive signal wire (red) to terminal 16.  
Connect a jumper wire between terminals 15 and 31.  
Connect the negative signal wire (black) to terminal 32.

For PV2 (downstream): Connect positive signal wire (red) to terminal 16.  
Connect jumper wire between terminals 15 and 28.  
Connect the negative signal wire (black) to terminal 29.

Refer to the full manual for instructions on accessing the following menus:

#### **IN THE CONFIGURATION MENU:**

Set CTR.TYPE to Standard, Set LINE.FREQ to 60, Set PV SOURCE to PV1-PV2, Set OUTPUT 2 to ALARM ON, Set OUTPUT 3 to ALARM ON, Define LOOP NAME if desired.

#### **IN THE PV1 MENU:**

Set PV1 TYPE to 4-20 mA, Set LOW RANGE to match low range of transducer, Set HI RANGE to match the full-scale range of transducers, Set RESTORE to manual.

#### **IN THE PV2 MENU:**

Set PV2SETUP to same as PV1.

#### **IN THE CONTROL MENU:**

Set ALGORITHM to On/Off, Set SOURCE to PV (differential), Set ACTION to DIRECT, Set PVBREAK to ON.

# NOTES

**IN THE ALARM 1 AND 2 MENUS:**

Set TYPE, SOURCE and MODE (latching or non-latching) as appropriate to the process. Set Alarm 1 OUTPUT to 2. This will cause its output to be at the output 2 terminals. Set Alarm 2 OUTPUT to 3. This will cause its output to be at the output 3 terminals. Set POWER UP as desired. If set to normal, the process will be powered up in the normal mode. If there is an alarm condition, the alarm will be activated. If set to ALARM, alarms will be activated on power up. If set to delayed, alarms will be inhibited regardless of whether or not an alarm condition exists. Define MESSAGE if desired.

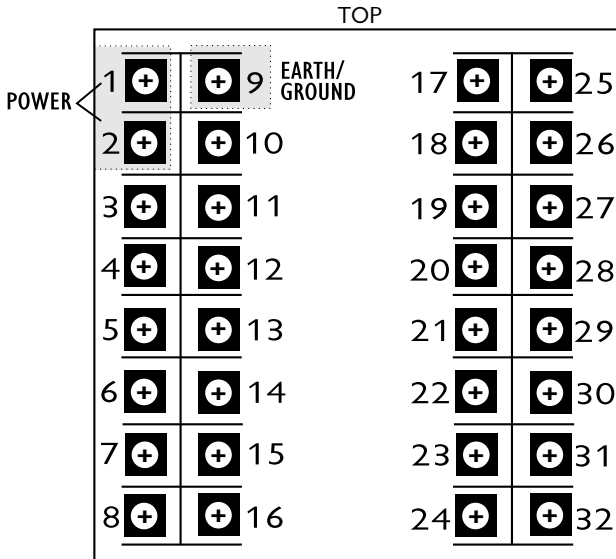
**IN THE SPECIAL MENU:**

Set the POWER UP to Manual.

**IN THE SECURITY MENU:**

Set the appropriate Security scheme for your application. The above setup will provide a display of the differential pressure, with its value controlling the main control output according to the operating setpoint value at terminals 3 and 4. Alarm 1 will output at terminals 5 and 6. Alarm 2 will output at terminals 7 and 8.

## DPC535 TERMINAL ASSIGNMENTS - DIFFERENTIAL PRESSURE CONTROL USING AMPLIFIED TRANSDUCERS



TERMINAL NUMBER	TRANSDUCER 1	TRANSDUCER 2
16	Signal + (Red)	Signal + (Red)
15	Jumper to 31	Jumper to 28
32	Signal - (Black)	N/A
29	N/A	Signal - (black)

Note that this wiring configuration applies to any differential measurement done with 4-20 mA, loop-powered transducers.

# Contents

## CHAPTER 1

<b>INTRODUCTION .....</b>	<b>1</b>
DPC 535 Modes .....	2
Order Code, Packaging Information .....	2
Where To Go Next .....	2
Text formatting in this manual .....	3

## CHAPTER 2

<b>BASIC INTERFACE .....</b>	<b>5</b>
Displays .....	5
Icons (Lit) .....	5
Keys .....	6
Basic Operating Procedures .....	7
Alarm Operation .....	9

## CHAPTER 3

<b>INSTALLATION .....</b>	<b>10</b>
Mounting the Controller .....	10
Wiring .....	11
AC Power Input .....	13
Process Variable Input .....	13
Output Modules .....	19
1. Mechanical Relay Output .....	19
2. Solid State Relay (Triac) Output .....	19
3. DC Logic (SSR Drive) Output .....	20
4. Milliamp Output .....	20
5. Position Proportioning Output .....	20
Serial Communications .....	21

## CHAPTER 4

<b>HARDWARE SET UP .....</b>	<b>22</b>
Hardware Input Types .....	23
The Process Variable .....	23
Mechanical Relays .....	24
Accessing and changing jumpers .....	25
Adding and Changing output modules .....	26
Special Communications Module .....	28

## Chapter 5

<b>SOFTWARE CONFIGURATION .....</b>	<b>29</b>
Menus .....	30
Parameters .....	31
Configuration and Operation .....	32
Where to Go Next .....	32
Text Formatting in This Manual .....	33
Software Menus and Parameters .....	33
CONFIG. ....	33
PV1 INPUT .....	36

PV2 INPUT .....	38
CUST. LINR. ....	40
CONTROL .....	42
ALARMS .....	43
RETRANS. ....	48
SELF TUNE .....	50
SPECIAL .....	52
SECURITY .....	53
SER. COMM. ....	54
Parameter Value Charts .....	57

## CHAPTER 6

<b>TUNING</b> .....	66
Overview .....	66
TUNING Menu Parameters .....	67
TUNING Parameter Value Chart .....	72
Self Tune Messages and Troubleshooting .....	74

## CHAPTER 7

<b>APPLICATIONS</b> .....	75
A. Control Type .....	75
B. Alarms .....	77
C. Duplex Control .....	81
Duplex with reverse and direct acting outputs .....	82
Duplex with direct and reverse acting outputs .....	83
Duplex with 2 reverse acting outputs .....	83
Duplex with a gap between outputs .....	83
Duplex with a overlapping outputs and output limits .....	84
Duplex with various relative gain settings .....	85
Duplex with one ON/OFF output .....	85
Duplex with two ON/OFF outputs .....	86
D. Staged Outputs .....	86
E. Retransmission .....	87
F. Multiple Setpoints .....	88
G. Multiple Sets of PID Values .....	88
H. Powerback .....	90
I. Self Tune—POWERTUNE® .....	90
Pretune by Itself .....	90
Pretune TYPE 1 and Adaptive Tune .....	93
Pretune TYPE 2 or TYPE 3 and Adaptive Tune .....	94
Adaptive Tune by Itself .....	95
Self Tune with Multiple Sets of PID .....	97
Self Tune with Time Proportioning Outputs .....	98
Self Tune with Control Valves .....	98
J. Ramp-to-Setpoint .....	98
K. Input Linearization .....	99
Thermocouple and RTD Linearization .....	99
Square Root Linearization .....	99
Custom Linearization .....	100
L. Load Line .....	101

### About This Manual:

Throughout this User's Manual information appears along the margins (**NOTE**, **CAUTION!** and **WARNING!**). Please heed these safety and good practice notices for the protection of you and your equipment.

### Your Comments:

We welcome your comments about this user's manual and encourage you to help us improve it. Please send your comments to:

**Marketing  
Communications  
Dynisco Instruments  
38 Forge Parkway  
Franklin, MA 02038**

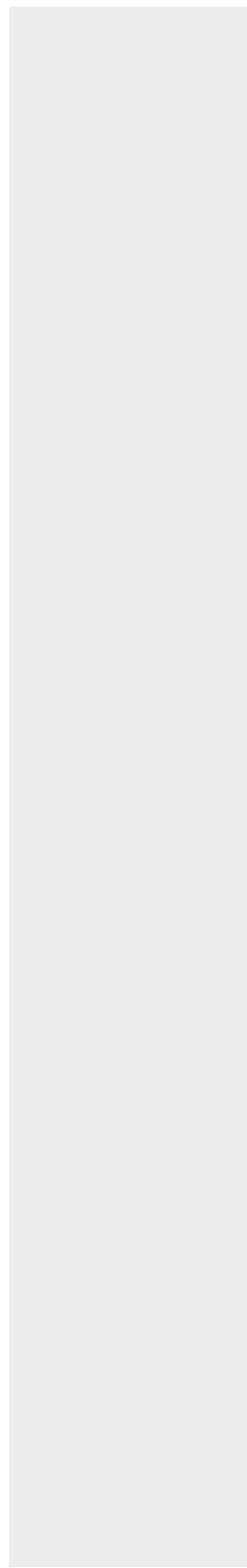
M. Security .....	102
N. Reset Inhibition .....	103
O. Process Variable Reading Correction .....	103
P. Serial Communications .....	104

<b>APPENDIX I</b>	
<b>    MENU FLOWCHARTS .....</b>	<b>106</b>

<b>APPENDIX 2</b>	
<b>    TROUBLESHOOTING .....</b>	<b>108</b>

<b>APPENDIX 3</b>	
<b>    SPECIFICATIONS .....</b>	<b>110</b>

<b>APPENDIX 4</b>	
<b>    GLOSSARY .....</b>	<b>117</b>





# List of Figures

<u>FIGURE</u>	<u>DESCRIPTION</u>	<u>PAGE</u>
Figure 2.1	..... Operator Interface .....	5
Figure 2.2	..... Before and After Acknowledging an Alarm .....	9
Figure 3.1	..... Instrument Panel & Cutout Dimensions .....	10
Figure 3.2	..... Attaching mounting collar .....	11
Figure 3.3	..... All 535 Terminal Assignments .....	12
Figure 3.4	..... AC Power Input Terminals .....	13
Figure 3.5	..... Process Variable Terminals .....	13
Figure 3.6	..... Differential Pressure Terminal Assignments Using Amplified Transducer .....	14
Figure 3.7	..... Differential Pressure Terminal Assignments Using Strain Gage Transducer .....	15
Figure 3.8	..... PV1 and PV2 Wiring for Milliamp, RTD and Voltage Inputs. ...	16
Figure 3.9	..... PV1 and PV2 Wiring for Milliamp Inputs with Internal and External Power Supply .....	17
Figure 3.10	... Interconnect Diagram Dual Strain Gage Input .....	18
Figure 3.11	... Mechanical Relay Output Wiring .....	19
Figure 3.12	... SSR Relay Output Wiring .....	19
Figure 3.13	... DC Logic Output Wiring .....	20
Figure 3.14	... Milliamp Output Wiring .....	20
Figure 3.15	... Serial Communications Terminals .....	21
Figure 4.1	..... Location of Printed Circuit Boards for Hardware Configuration .....	22
Figure 4.2	..... The Microcontroller Circuit Board, the Option Board, and the Power Supply Board .....	24
Figure 4.3	..... Representation of Module .....	28
Figure 4.4	..... Install Communications Module onto Microcontroller Board .....	28
Figure 5.1	..... Menu Flowchart for Set Up .....	29
Figure 5.2	..... Independent vs. Dependent Parameters .....	28
Figure 5.3	..... Configuration Flowchart .....	31
Figure 6.1	..... Access the Tuning Menu Block .....	66
Figure 7.1	..... Alarm Examples .....	80
Figure 7.2	..... Duplex with reverse and direct acting outputs .....	82
Figure 7.3	..... Duplex with direct and reverse acting outputs .....	83
Figure 7.4	..... Duplex with two reverse acting outputs .....	83
Figure 7.5	..... Duplex with a gap between outputs .....	84
Figure 7.6	..... Duplex with overlapping outputs and output limits .....	84
Figure 7.7	..... Duplex with various relative gain settings .....	85
Figure 7.8	..... Duplex with one ON/OFF output .....	85
Figure 7.9	..... Duplex with two ON/OFF outputs .....	86
Figure 7.10	... Staged Outputs Example .....	86
Figure 7.11	... Pretune TYPE 1, 2 and 3 with Adaptive Tune .....	92
Figure 7.12	... Noise Band Calculation Example .....	95
Figure 7.13	... Noise Band Values for Temperature Inputs .....	96
Figure 7.14	... Deadtime and Time Constant .....	96
Figure 7.15	... Square Root Linearization Formula .....	100
Figure 7.16	... 15-point Linearization Curve .....	100
Figure 7.17	... Load Line Example .....	101

## 1. INTRODUCTION



From its surge-resistant power supply to its rugged construction, the DPC 535 process controller is designed to ensure the integrity of your process with maximum reliability — hour after hour, day after day. The isolated inputs and outputs guard against the dangers of electrical interference, the front face meets NEMA 4X standards for watertight operation and exposure to corrosive environments, and the solid metal housing and sturdy rubber keys enhance durability and ESD protection.

The DPC 535 has been engineered to be the industry's most user-friendly process controller. With three digital display areas — two offering up to 9 characters of true alphanumeric — the DPC 535 effectively eliminates the cryptic messages that could confuse even the most experienced operator. The bright, crisp display is vacuum fluorescent, and offers much better readability than any other display technology. Additional operator-friendly features include: custom programmable alarm messages, illuminated keys, and an easy-to-use menu system.

The DPC 535 is the most accurate instrument in its class. With a sampling rate of ten times per second, it is ideal for demanding pressure and flow applications. The DPC 535 also offers a universal process input and modular, field interchangeable outputs that allow more flexibility than ever before. The RS-485 serial communications interface allows the controller to utilize sophisticated software routines and high speed hardware to provide exceptionally fast and accurate transmission of data. The DPC 535 also offers sophisticated control algorithms, including our **exclusive Adaptive Tune** which constantly analyzes your process and makes modifications to the tuning parameters to ensure you're always under control.

*Thank you for selecting the DPC 535 Process Controller — the most sophisticated instrument in its class. It will provide you with years of reliable, trouble-free performance.*

## **DPC 535 MODES**

There are three operating modes for the DPC 535 controller: **OPERATION**, the default mode of the controller. When the DPC 535 is operating, you can change setpoints, select manual control and change output level, acknowledge alarms and monitor conditions.

**SET UP**, also referred to as configuration. Here you set up the basic functions of the instrument such as input and output assignments, alarm types and special functions.

**TUNING**, where you configure control function parameters for Proportional, Integral and Derivation (PID). Use periodically to optimize the control performance of the instrument.

## **ORDER CODE, PACKAGING INFORMATION**

Compare the product number to the ordering code on page 3 to determine the outputs and options installed on the DPC 535. The product number is printed on the label on the top of the controller case.

Included with this DPC 535 are:

- a DPC 535 User's Manual
- mounting hardware
- 1 sheet of Engineering unit adhesive labels

## **WHERE TO GO NEXT**

- To become more familiar with the DPC 535 interface, continue to Chapter 2.
- For important hardware installation guidelines, see Chapters 3 and 4.
- For a detailed description of all the software menus and parameters of the DPC 535, follow through Chapters 5 and 6. Appendix 1 can be used as a basic guideline to these parameters.

## TEXT FORMATTING IN THIS MANUAL

### Feature

### Format

#### **KEYS**

#### **SET PT**

#### **DISPLAY**

or

**SET PT**

**DISPLAY**

#### **ICONS**

OUT, ALM

#### **MENUS**

CONFIG., TUNING,

#### **PARAMETERS**

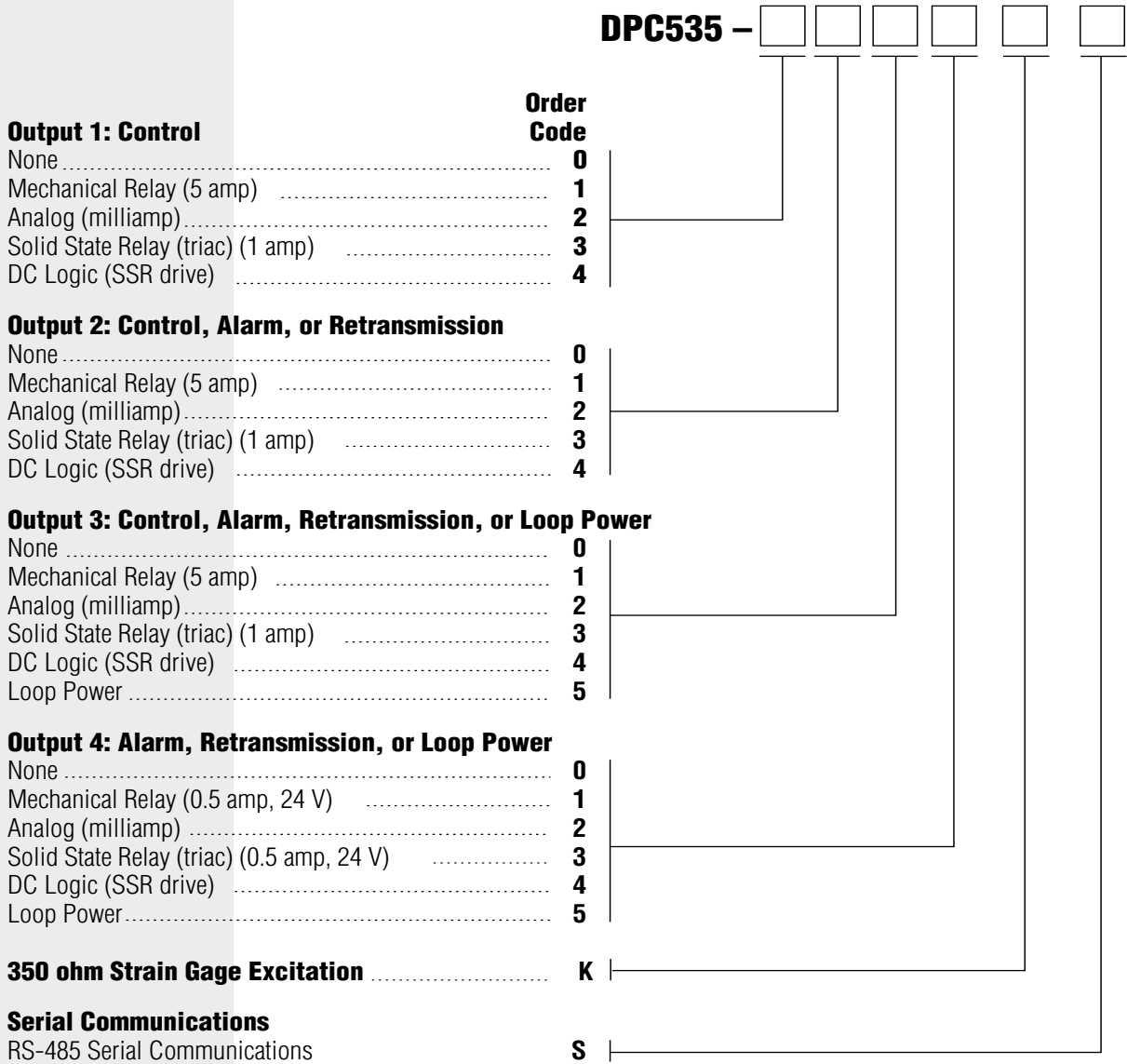
CYCLE TM:1, MIN.OUT2

#### **PARAMETER VALUES**

OFF, SETPOINT, LAST OUT.

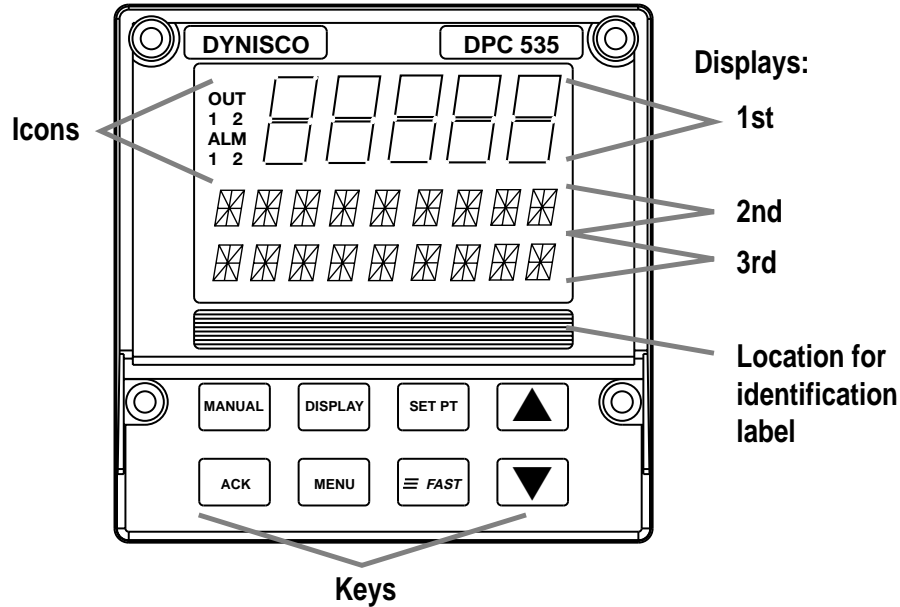
#### **DISPLAY MESSAGES**

TOO HOT, OUT%,



**Note 1:** Up to two outputs may be used for alarms. **Note 2:** All outputs are interchangeable modules. **Note 3:** The mechanical relay and solid state relay modules are derated to 0.5 amp at 24 Vac when used as the fourth output.

## 2. BASIC INTERFACE



**Fig. 2.1 Operator Interface**

### DISPLAYS

The display strategy of the DPC 535 Process Controller is the same for all control modes.

#### 1st Display (five 7-segment digits)

- For the process variable value.

#### 2nd Display (nine 14-segment digits)

- For the setpoint, deviation, output level or valve position (if available)
- In **TUNING** or **SET UP** mode, for the parameter name.
- Upon power up, indicates the current setpoint.

#### 3rd Display (nine 14-segment digits)

- For alarm messages, loop name, errors, etc.
- In **TUNING** or **SET UP** mode, the value or choice of parameter shown in the 2nd display.

## ICONS (LIT)

**OUT** Indicates either 1) relay output is energized; or 2) analog output is greater than 0%.

**ALM1** Indicates the respective alarm (one) is active.

**ALM2** Indicates the respective alarm (two) is active.

<b>OUT</b> 1	<b>OUT</b> 2	<b>OUT</b> 1 2
<b>ALM</b> 1	<b>ALM</b> 2	<b>ALM</b> 1 2

## KEYS

**FAST**

**FAST:** Has no independent function. Press to modify the function of another key (see below).

**MANUAL**

**MANUAL :** Press to toggle between manual and automatic control. When lit, indicates the unit is under manual control.

**SET PT**

**SET PT :** Press to select the active SP. When lit, indicates that a setpoint other than the primary (e.g., RSP, SP2) is active.

**DISPLAY**

**DISPLAY :** Press to toggle through values in the 2nd display for setpoint, ramping setpoint, deviation, PV1, PV2, output and valve position (each, if available).

In Tuning or Set Up mode, press to return controller to Operation mode (display will show current setpoint).

**▲**

**▲ :** Press to increase the value or selection of displayed parameter.

**FAST**

+

**▲**

**FAST+▲ :** Press to scroll through values at a faster rate.

**▼**

**▼ :** Press to decrease the value or selection of displayed parameter.

**FAST**

+

**▼**

**FAST+▼ :** Press to scroll through values at a faster rate.

**ACK**

**ACK :** Press to acknowledge (an) alarm(s). When lit, indicates there is an acknowledgeable alarm.

**MENU**

**MENU :** In Operation Mode, press to access the Tuning Menu. In Set Up or Tuning mode, press to advance through a menu's parameters. (Use **FAST+MENU** to advance to the next menu.) When lit, indicates the controller is in Set Up mode.

**FAST+MENU :** Press to access the Set Up menus.



In Set Up mode, press to advance through menus. (Use **MENU** by itself to access the parameters of a particular menu.)

## **BASIC OPERATING PROCEDURES**

Use the following as a quick guide to key operating functions of the DPC 535.

### **To select /change a setpoint**

1. Use **DISPLAY** key to toggle display to Set Point.
2. Use **SET PT** key to toggle to active setpoint. Before the newly selected setpoint is made active, there is two-second delay to prevent any disruptive bumps. If the setpoint displayed is ramping, RAMPING will show the 3rd display.
3. To change value, press ▲ or ▼.

### **To change from auto to manual control (bumpless transfer)**

1. When in automatic control, press the **MANUAL** key at any time, except while in the TUNING mode.
2. The **MANUAL** key will light in red, and the 2nd display will immediately change to indicate current output level.

### **To change from manual to auto**

1. When in manual control, press **MANUAL** at any time except while in the TUNING or SET UP mode.
2. The 2nd display will not change, and the **MANUAL** key will no longer be lit once control changes.

### **To change manual output values**

1. Make sure the controller is under manual control.
2. Use the **DISPLAY** key to toggle 2nd display to output level.
3. Use the ▲ or ▼ key to change the value.

### **To override security**

If a locked operation is attempted, SECURITY appears in the 2nd display for two seconds).



1. Use the ▲ and ▼ keys to quickly enter the security code, which will show in the 3rd display. The starting value is 0.

**Note:** Two seconds of key inactivity will clear the display.

2. If the code is correct, CORRECT appears in the 3rd display. The display will clear after two seconds, allowing full access.
4. If code is incorrect, INCORRECT appears in the 3rd display. INCORRECT will disappear after two seconds, and a new security code can then be entered.
5. The controller will revert back to full security lock after one minute of key inactivity.

#### **To display control output value**

1. Toggle **DISPLAY** key until the 2nd display shows OUT followed by the output percentage. This value is the PID output.
  - In duplex applications, this value does not directly refer to the output signal (refer to the Chapter 7 section on Duplex Control for details.)
  - For on/off outputs, the output value shown is either ON or OFF.
  - For duplex applications with two on/off outputs, the OUT tag is not shown. In this case, the status of both outputs is shown in the following manner: 1:ON 2:OFF (1 and 2 are the respective outputs).

#### **To display the active PID set**

1. Press **MENU** to reach Tuning Mode.
2. In **TUNING** Mode, press **MENU** to reach the correct Menu parameter.
3. The active PID set will have an asterisk (\*) on both sides of the value.

## ALARM OPERATION

Alarms may be used in systems to provide warnings of unsafe conditions.

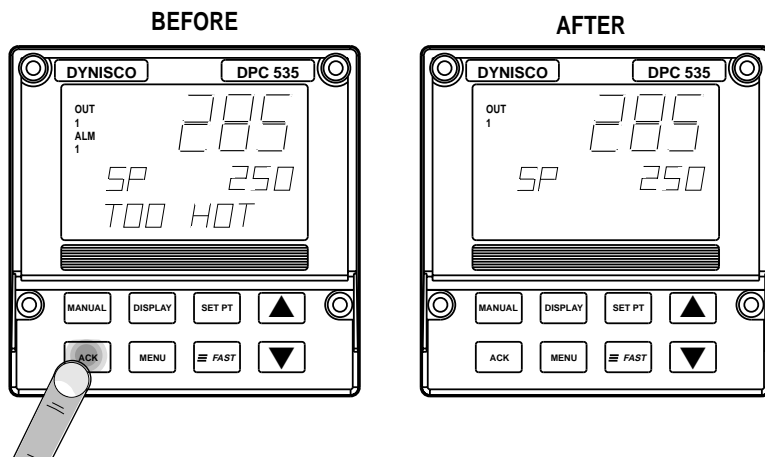
All DPC 535 operators must know how the alarms are configured, the consequences of acknowledging an alarm and how to react to alarm conditions.

### Alarm Indication

- lit icons **ALM 1** and/or **ALM 2**
- lit **ACK** key
- displayed alarm message

**Acknowledgable** alarms meet the first two of these conditions.

**Non-acknowledgable** alarms only meet the first condition



**Fig. 2.2 Before and After Acknowledging an Alarm**

### To acknowledge an alarm(s):

1. To acknowledge Alarm 1, press **ACK** once.
2. To acknowledge Alarm 2, press **ACK** twice.
3. If both alarms are activated, press **ACK** once to acknowledge Alarm 1, then again to acknowledge Alarm 2.
4. The message and alarm icon disappear.

### Latching Alarms

If an alarm is set up to be latching (for details, see Chapter 5) then, in general, it must be acknowledged in order to clear the alarm and release the relay (if applicable). A non-latching alarm will clear itself as soon as the process leaves the alarm condition.

### NOTE:

All alarms are software alarms unless tied to an output relay in the **SET UP** mode. See Chapters 5 and 7 for details on alarms.

### NOTE:

Powering down the DPC 535 acknowledges/clears all latched alarms. When powering up, all alarms will be reinitialized.

### Limit Sequence

An alarm can be configured to be both latching and non-acknowledgeable. In this case, the alarm is acknowledgeable only after the process has left the alarm condition. This is similar to the function of a limit controller.

### More on Alarms

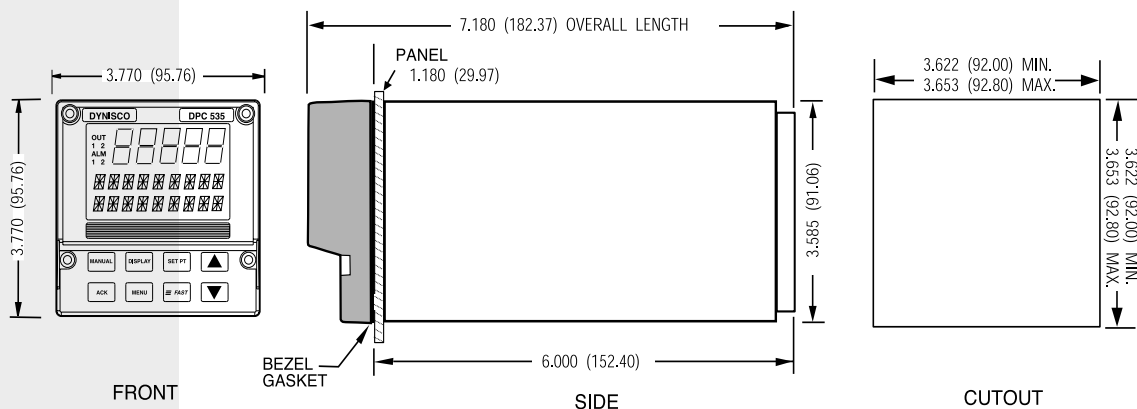
For more details on how to set up alarms and for examples of various ways alarms can be set up, refer to the section on Alarms in Chapter 7.

## 3. INSTALLATION

### MOUNTING THE CONTROLLER

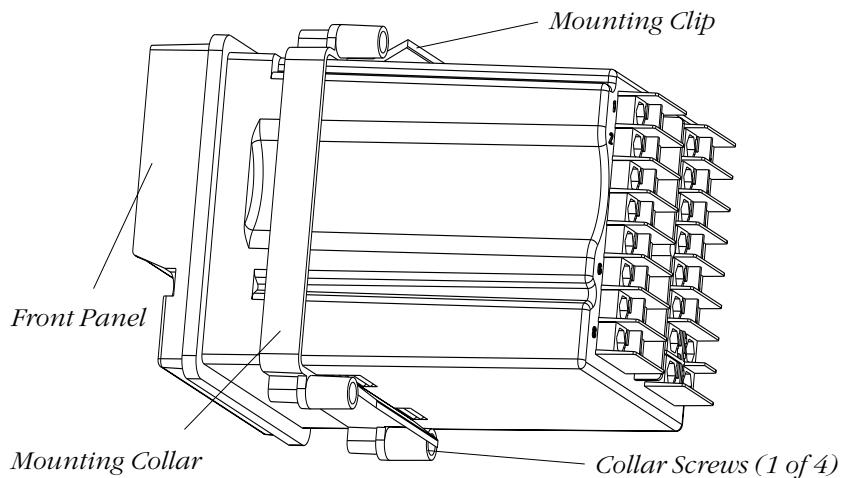
The DPC 535 front face is **NEMA 4X rated** (waterproof). To obtain a waterproof seal between the controller and the panel, follow these directions:

1. The DPC 535 fits in a standard 1/4 DIN cutout. Mount the DPC 535 in any panel with a thickness from .06 in. to .275 in. (1.5 mm to 7.0 mm).



**Fig. 3.1 Instrument Panel & Cutout Dimensions**

2. Figure 3.1 shows the controller and panel dimensions. The panel cutout must be precise, and the edges free from burrs and waves.
3. Place bezel gasket around the controller case (starting at the back of controller). Then, slide the gasket against the back of the bezel.
4. With the bezel gasket in place, insert the DPC 535 into the panel cutout from the front of the panel.
5. Slide the mounting collar over the back of the case, as shown in Figure 3.2. The collar clip edges will lock with matching edges on the controller case.



**Fig. 3.2 Attaching mounting collar**

6. Insert the four mounting collar screws from the rear of the collar. Gradually tighten the screws (using a Phillips #2 screwdriver) to secure the controller against the panel.
7. If there is difficulty with any of the mounting requirements, apply a bead of caulk or silicone sealant behind the panel around the perimeter of the case

## WIRING

DPC 535 controllers are thoroughly tested, calibrated and “burned in” at the factory, so the controller is ready to install. Before beginning, read this chapter thoroughly and take great care in planning a system. A properly designed system can help prevent problems such as electrical noise disturbances and dangerous extreme conditions.

1. For improved electrical noise immunity, install the DPC 535 as far away as possible from motors, relays and other similar noise generators.
2. Do not run low power (sensor input) lines in the same bundle as AC power lines. Grouping these lines in the same bundle can create electrical noise interference.
3. All wiring and fusing should conform to the National Electric Code and to any locally applicable codes.

### **CAUTION!**

The enclosure into which the DPC 535 Controller is mounted must be grounded according to CSA standard C22.2 No. 0.4.

### **WARNING!**

Avoid electrical shock. Do not connect AC power wiring at the source distribution panel until all wiring connections are complete.

- An excellent resource about good wiring practices is the IEEE Standard No. 518-1982 and is available from IEEE, Inc., 345 East 47th Street, New York, NY 10017, (212) 705-7900.

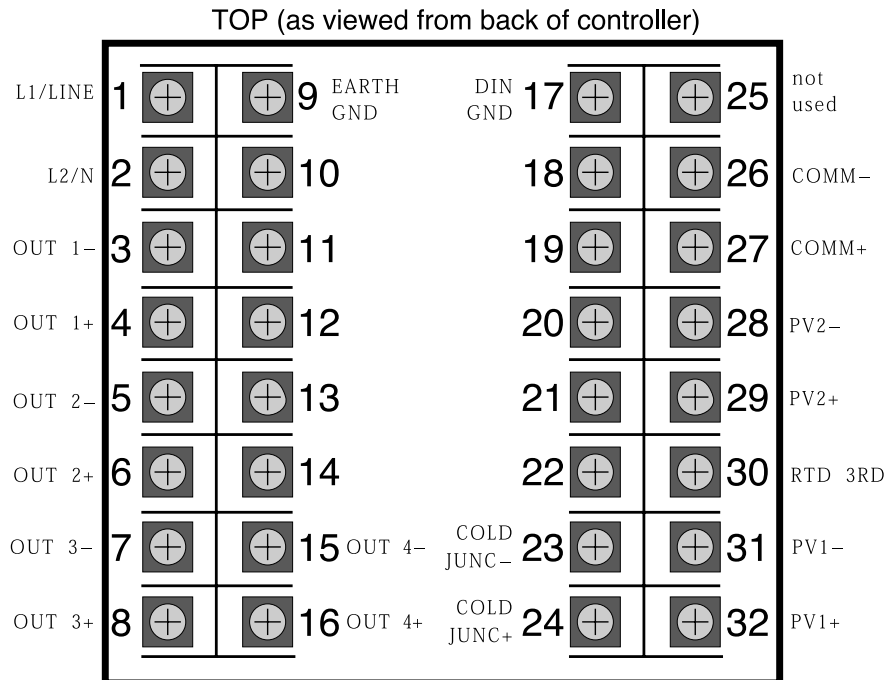
Diagrams on the next three pages serve as guides for wiring different types of process inputs. The shaded areas on the diagrams show which rear terminals are used for that type of wiring.

**WARNING!  
ELECTRIC  
SHOCK  
HAZARD!**

Terminals 1 and 2 carry live power. DO NOT touch these terminals when power is on.

**WARNING!**

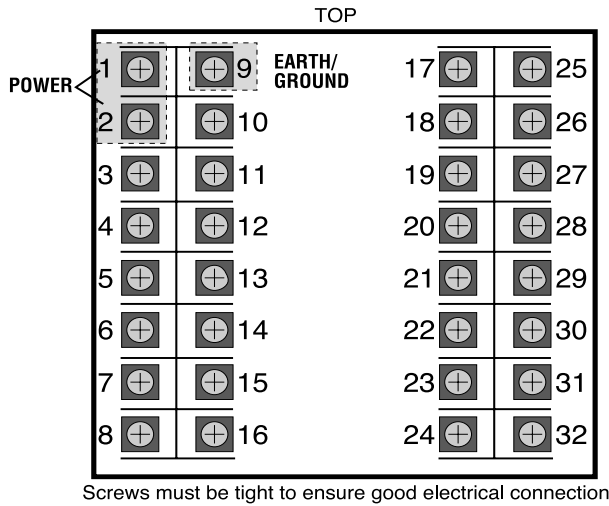
Terminal 9 must be grounded to avoid potential shock hazard, and improved noise immunity to your system.



**Fig. 3.3 All DPC Terminal Assignments Actual DPC 535 device only has top and bottom numbers of each column of terminals marked.**

### AC POWER INPUT

Terminals 1 and 2 are for **power**. Terminal 9 is the **earth ground**. Use a 0.5 Amp, 250 V, fast-acting fuse in line with your AC power connection.



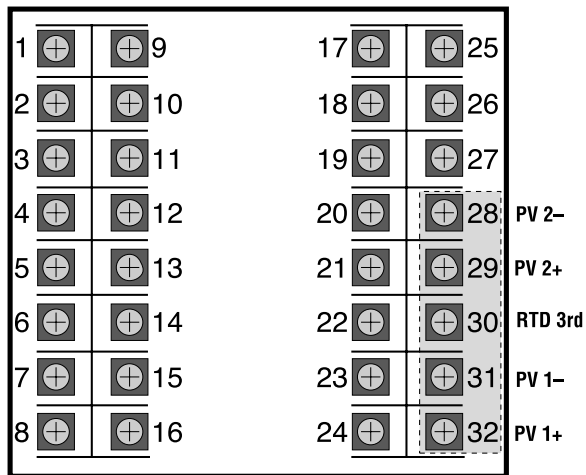
**Fig. 3.4 AC Power Input Terminals**

### PROCESS VARIABLE INPUT

The DPC 535 accommodates the following types of process variable inputs:

- Thermocouple Input
- RTD Input
- Voltage Input
- Milliamp Input with External Power Supply
- Milliamp Input with Internal Power Supply
- Differential Strain Gage Input with Internal Power Supply

Each type of input can be wired for PV1 (terminals 31 and 32) or for PV2 (terminals 28 and 29).



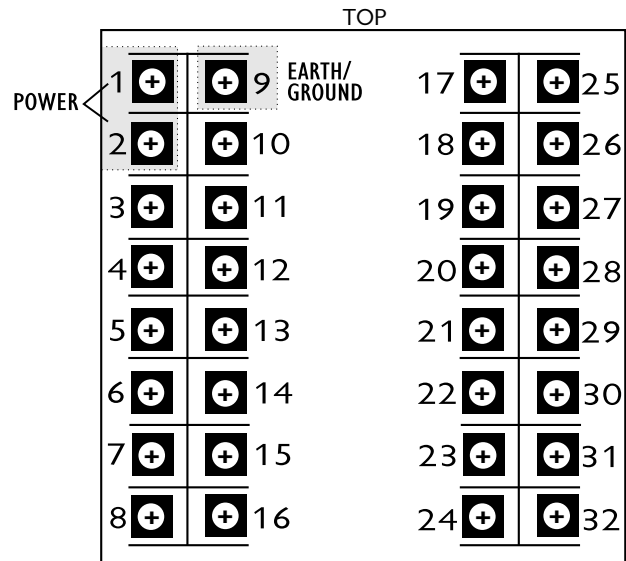
**Fig. 3.5 Process Variable Terminals**

When wiring to a 240 V System, external fuses are required on L1 and L2.

**CAUTION!**

Do not run low power (sensor input) lines in the same bundle as AC power lines. Grouping these lines in the same bundle can create electrical noise interference.

**Fig. 3.6 DPC535 Terminal Assignments - Differential Pressure Control Using Amplified Transducers**

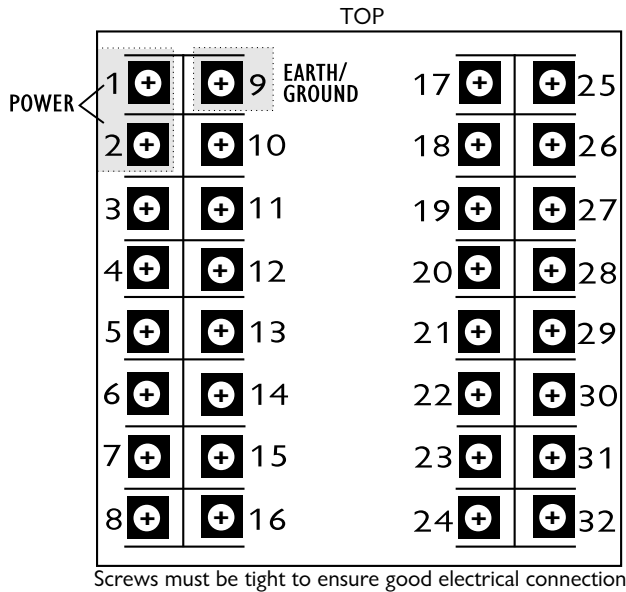


Screws must be tight to ensure good electrical connection

TERMINAL NUMBER	TRANSDUCER 1	TRANSDUCER 2
16	Signal + (Red)	Signal + (Red)
15	Jumper to 31	Jumper to 28
32	Signal - (Black)	N/A
29	N/A	Signal - (black)

Note that this wiring configuration applies to any differential measurement done with 4-20 mA, loop-powered transducers.

**Fig. 3.7 DPC535 Terminal Assignments - Differential Strain Gage Inputs**



TERMINAL NUMBER	TRANSDUCER 1	TRANSDUCER 2
10	Excitation - (Green) Calibration (Blue)	Excitation - (Green) Calibration (Blue)
11	Excitation +(White)	Excitation +(White)
12	Calibration (Orange)	N/A
22	N/A	Calibration (Orange)
28	N/A	Signal - (Black)
29	N/A	Signal + (Red)
31	Signal - (Black)	N/A
32	Signal + (Red)	N/A

For single Strain Gage Transducer input, wire as shown under Transducer 1 only.

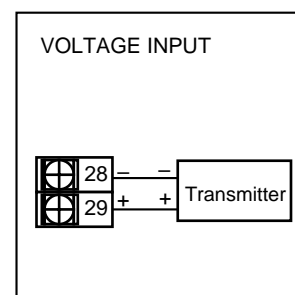
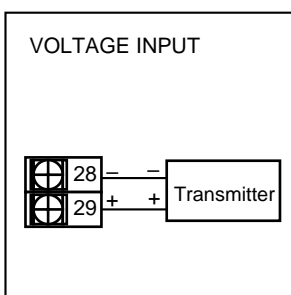
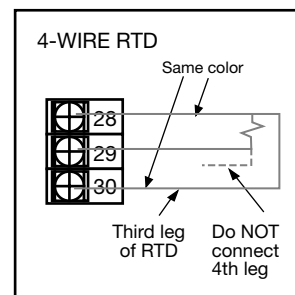
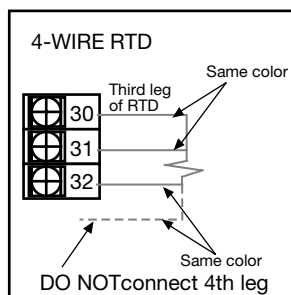
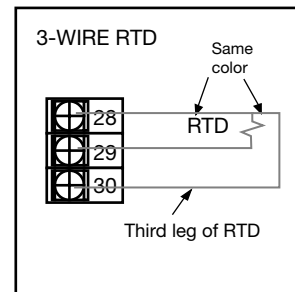
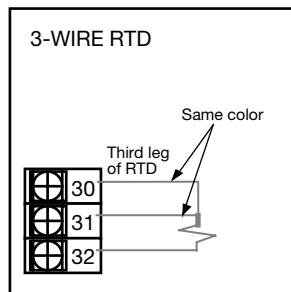
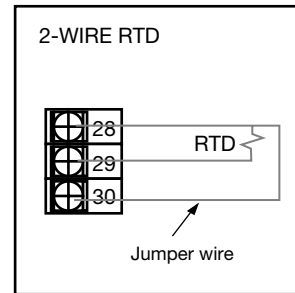
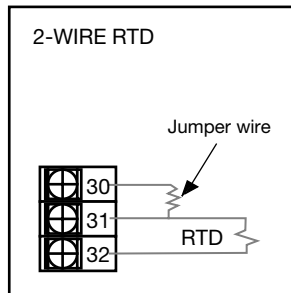
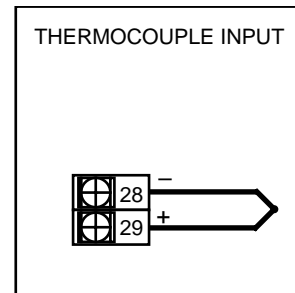
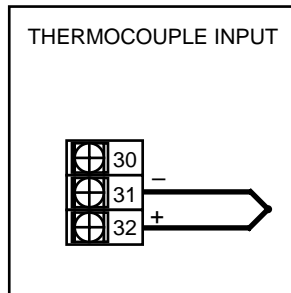


**NOTE:**

Typically, in the U.S., negative leads are red.

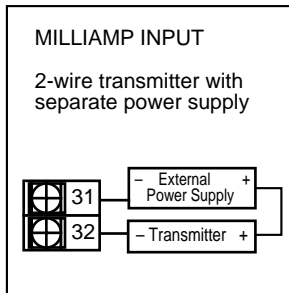
**For PV1**

**For PV2**

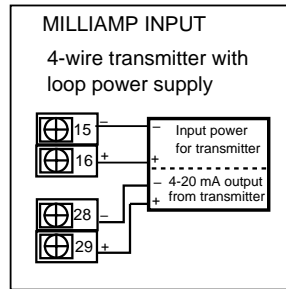
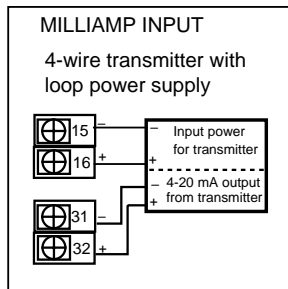
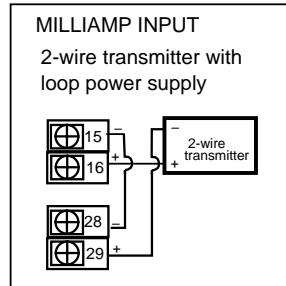
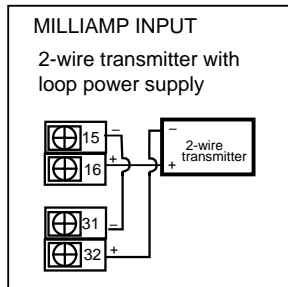
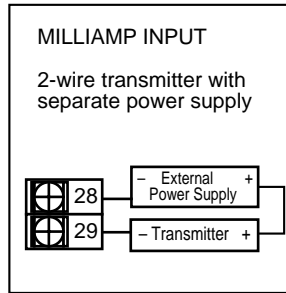


**Fig. 3.8 PV1 and PV2 Wiring for Milliamp, RTD and Voltage Inputs.**

**For PV1**



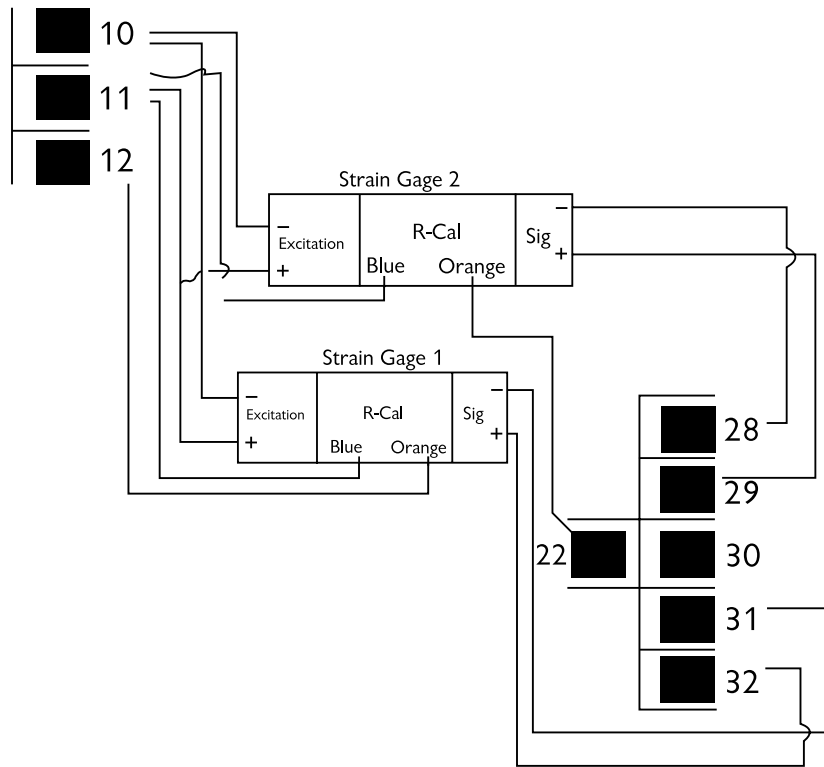
**For PV2**



**NOTE:**

To use loop power, there must be a loop power module installed in the 3rd or 4th output socket. Compare the controller product number with the order code in Chapter 1 to determine if the DPC 535 has a loop power module installed. To install a loop power module, refer to Chapter 4.

**Fig. 3.9 PV1 and PV2 Wiring for Milliamp Inputs with Internal and External Power Supply**



**Fig. 3.10 Interconnect Diagram Dual Strain Gage Input**

## OUTPUT MODULES

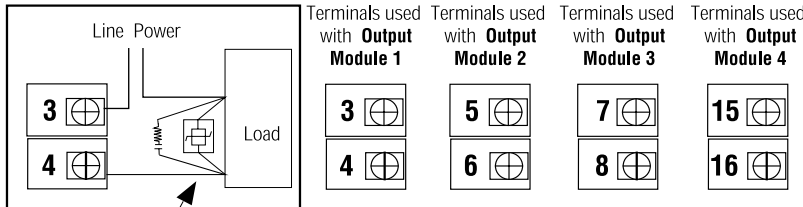
The DPC 535 output modules are used for control, alarms and retransmission. The four output module types are: **Mechanical** Relay, **Solid State** Relay (Triac), **DC Logic** (SSR Drive) and **Analog** (Milliamp)

To install these modules, plug them into any of the four output sockets on the printed circuit boards (refer to Chapter 4). The wiring is the same whether the modules are used for control, alarm or retransmission.

The diagrams on the next two pages are a guide for properly connecting the various outputs. To find out which module(s) have been installed in the controller, compare the product number on the controller label with the section Order Code in Chapter 1. This section also includes a diagram of how to wire a position proportioning output, a special application using two mechanical or two solid state relays.

### 1. Mechanical Relay Output

- Output 1 is always Control 1.
- Outputs 1, 2 and 3 are jumper selectable for normally open and normally closed on the power supply circuit board.
- Output 4 is always configured for normally open and has reduced voltage and current ratings (see Specifications).

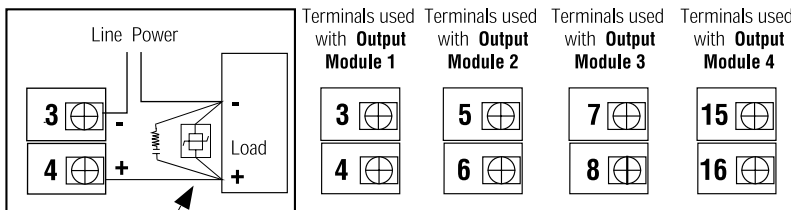


Recommend use of both MOV and snubber

**Fig. 3.11 Mechanical Relay Output wiring**

### 2. Solid State Relay (Triac) Output

- Output 1 is always Control 1.
- Respective jumper J1, J2 or J3 must be set to normally open for SSR (Triac) output.
- Output 4 is always configured for normally open and has reduced voltage and current ratings (see Specifications).



Recommend use of both MOV and snubber

**Fig. 3.12 SSR Relay Output Wiring**

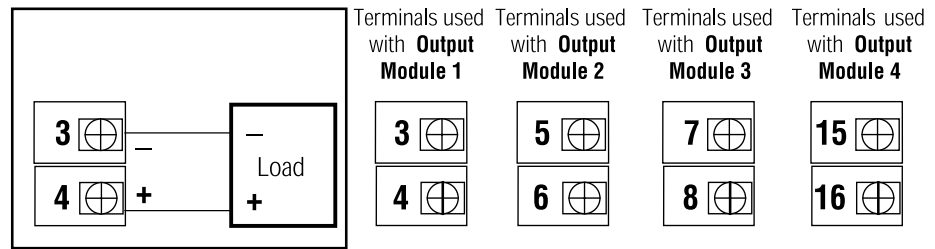
**NOTE:**

Refer to Figure 4.2 for location of the corresponding jumpers.

Second input jumper connector on the option board must be in either mA (milliamp) or V (voltage) position.

### 3. DC Logic (SSR Drive) Output

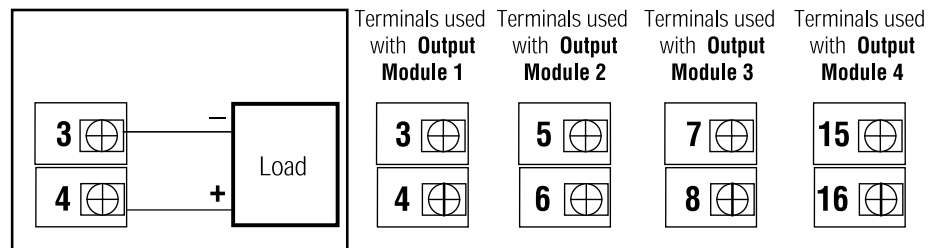
- Output 1 is always Control 1.
- Respective jumper J1, J2 or J3 must be set to normally open for DC Logic output.
- Output 4 is always configured for normally open.



**Fig. 3.13 DC Logic Output Wiring**

### 4. Milliamp Output

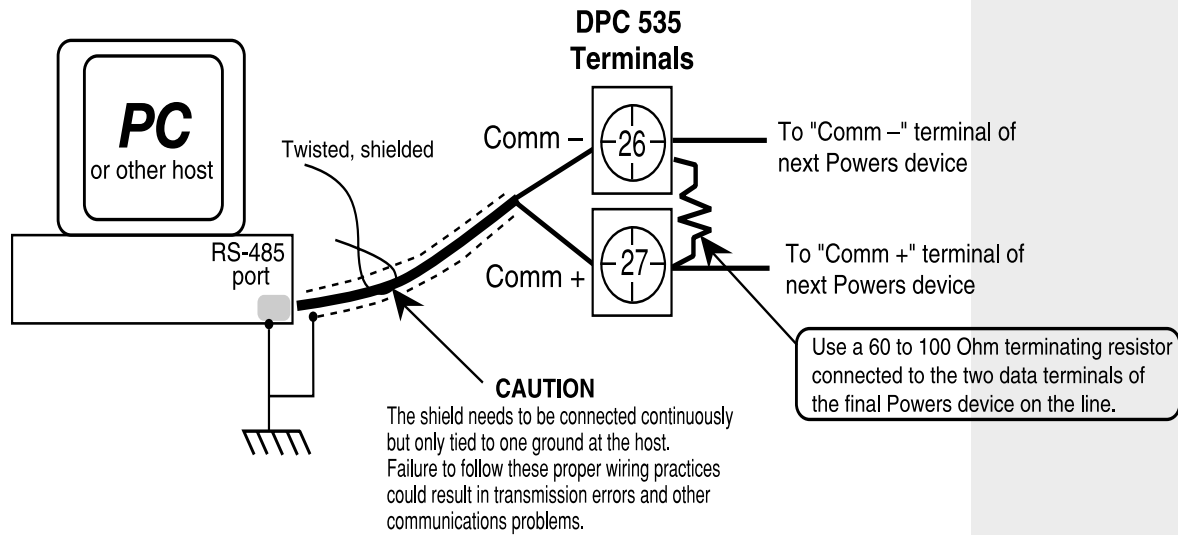
- Output 1 is always Control 1.
- Respective jumper J1, J2 or J3 must be set to normally open for Milliamp output.



**Fig. 3.14 Milliamp Output Wiring**

## SERIAL COMMUNICATIONS

A twisted shielded pair of wires should be used to interconnect the host and field units. Belden #9414 foil shield or #8441 braid shield 22-gauge wire are acceptable for most applications. The foil shielded wire has superior noise rejection characteristics. The braid shielded wire has more flexibility. The maximum recommended length of the RS 485 line is 4000 feet. Termination resistors are required at the host and the last device on the line. Some RS 485 cards/converters already have a terminating resistor. The communication protocol is asynchronous bidirectional half-duplex, hence the leads are labelled *Comm +* and *Comm -*.



**Fig. 3.15 Serial Communications Terminals**

## 4. HARDWARE SET UP

Hardware configuration determines the available outputs as well as the type of input signal. The DPC 535 controller comes factory set with the following:

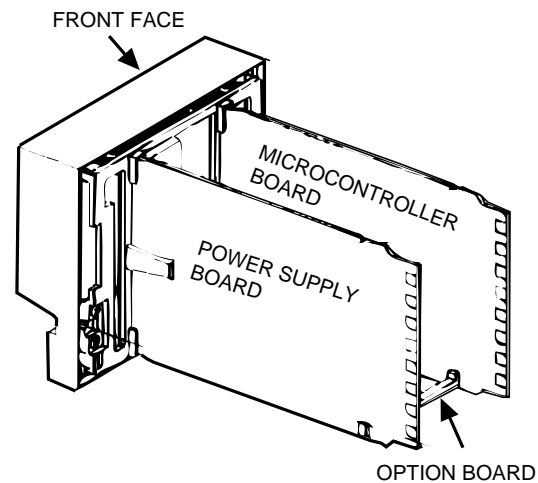
- All specified module and options installed (for details, refer to the Order Code in Chapter 1).
- Process variable and remote setpoint set to accept a milliamp input
- Relay outputs set to normally open.

**NOTE:**

Hardware configuration of the controller is available at the factory; Consult a Dynisco application engineer for details.

Alter the factory configuration of the DPC 535, requires accessing the circuit boards, and locating the jumpers and output modules (see Figure 4.1).

1. With the power off, loosen the four front screws, and remove them.
2. Slide chassis out of the case by pulling firmly on the bezel.



**Fig. 4.1 Location of Printed Circuit Boards for Hardware Configuration**

A detailed view of the circuit boards appears in Figure 4.2.

After configuring the hardware, or if no changes are necessary, continued setting up the process as needed.

## **HARDWARE INPUT TYPES**

### **The Process Variable**

The DPC 535 accepts several different types of process variable signals. Set a jumper location to specify the type of input signal. Set the signal range in the software (see Chapter 5 for software menus, or Chapter 7 for applications).

The jumpers for the process variable are located on the Microcontroller Circuit Board (see Figure 4.2). The factory default is Milliamp. Locations are marked as follows:

- V Voltage (Includes 3.33 mV/V Strain Gage)
- MA Milliamp
- TC ▼ Thermocouple with downscale burnout
- TC ▲ Thermocouple with upscale burnout
- RTD RTD

### **NOTE:**

*Thermocouple downscale and upscale burnout offers a choice in which direction the controller would react in the event of thermocouple failure. For example, in heat applications, typically, it is desirable to fail upscale (TC s) so that the system does not apply more heat.*

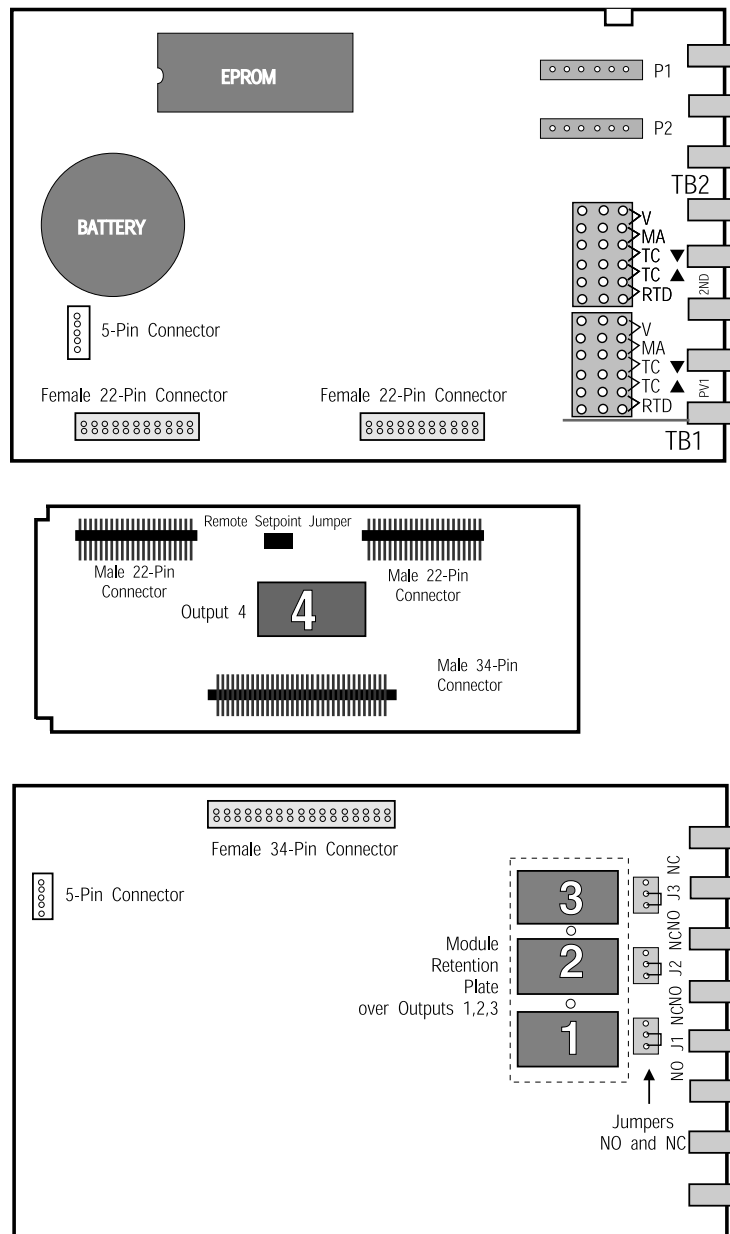


**Note:**

Changing the jumpers means moving the jumper connector. The jumper connector slips over the pins, straddling two rows of pins. The printed circuit boards are labeled next to the jumpers.

**Mechanical Relays**

There are three output module sockets on the Power Supply Circuit Board, and one output module on the Option Board (see Figure 4.2). The mechanical relay on the Power Supply Board may be configured for either normally open (NO) or normally closed (NC). A jumper located next to each socket determines this configuration. All relay output are factory set to NO (normally open).



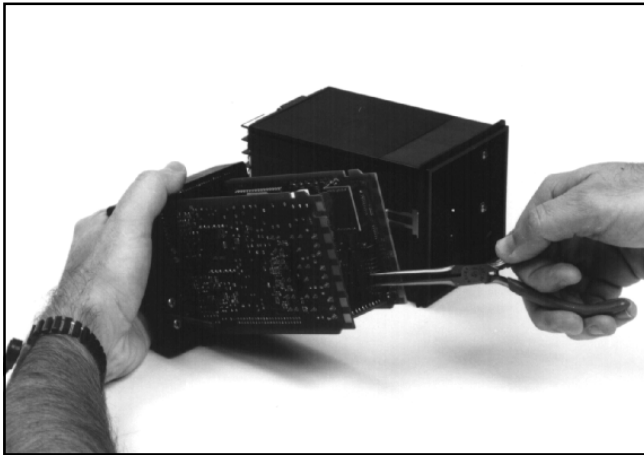
**Fig. 4.2 (from the top) The Microcontroller Circuit Board, the Option Board, and the Power Supply Board**

## ACCESSING AND CHANGING JUMPERS

Follow these instruction to change jumpers for the Process Variable, Remote Setpoint and Digital Inputs:

Equipment needed:     Needle-nose pliers (optional)  
                              Phillips screwdriver (#2)  
                              Wrist grounding strap

1. With power off, loosen four front screws, and remove them.
2. Side the chassis out of the case by pulling firmly on the bezel.
3. Use *Figure 4.2* to locate the jumper connector to change.
4. Using the needle nose pliers (or fingers), pull straight up on the connector and remove it from its pins, as shown in *Photo 4*. Be careful not to bend the pins.
5. Find the new location of the jumper connector (again, refer to *Figure 3.2*). Carefully place it over the pins, then press connector straight down. Make sure it is seated firmly on the pins.



**4. Remove Jumpers**

6. Make any other jumper changes as needed. **To alter output modules I, please refer to the next section, starting with Step #3.**
7. To reassemble the controller, properly orient the chassis with board opening on top. Align the circuit boards into the grooves on the top and bottom of the case. Press firmly on the front face assembly until the chassis is all the way into the case.  
  
If it is difficult to slide the chassis in all the way, make sure the screws have been removed (they can block proper alignment), and that the chassis is properly oriented.
8. Carefully insert and align screws. Tighten them until the bezel is seated firmly against the gasket. **Do not overtighten.**

### **CAUTION!!**

*Static discharge can cause damage to equipment. Always use a wrist grounding strap when handling electronics to prevent static discharge.*

## ADDING AND CHANGING OUTPUT MODULES

The DPC 535 has provisions for four output modules. A controller ordered with output module options already has the modules properly installed. Follow these instruction to add modules, change module type(s) or change module location(s).

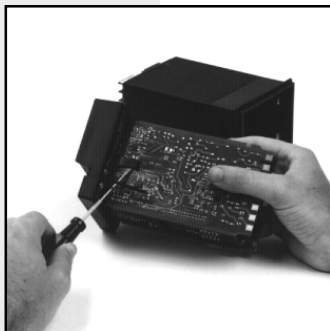
Equipment needed:      Wrist grounding strap  
                                 Phillips screwdriver (#2)  
                                 Small flat blade screwdriver  
                                 Wire cutters

1. With power off, loosen four front screws, and remove them.
2. Side the chassis out of the case by pulling firmly on the bezel.
3. Use a flat screwdriver to carefully pry apart the clips that hold the front face assembly to the chassis, as in Photo 3. Separate the printed circuit board assembly from the front face assembly. Use care not to break the clips or scratch the circuit boards.
4. As shown in *Photo 4*, carefully pry apart, using hands or a small flat screwdriver, the smaller Option board and the Power Supply board (the one with 3 modules).

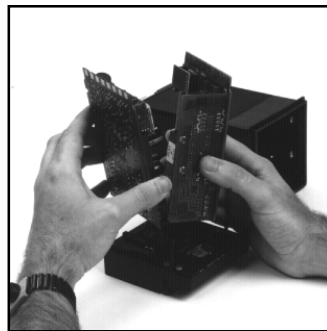
5. **To change modules 1, 2 or 3:**

Output modules 1, 2, and 3 are firmly held in place by a retention plate and tie wrap. Carefully snip the tie wrap with a wire cutter. To prevent damage to the surface mount components, ALWAYS snip the tie wrap on TOP of the Retention Plate, as shown in Photo 5.

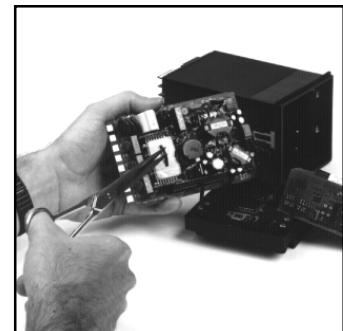
Remove the retention plate.



3. Pry Clips



4. Separate Boards

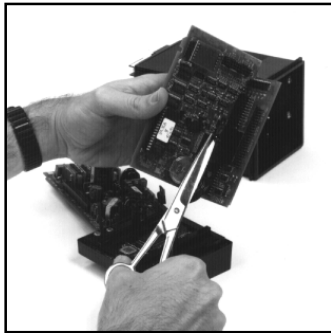


5. Remove Retention Plate

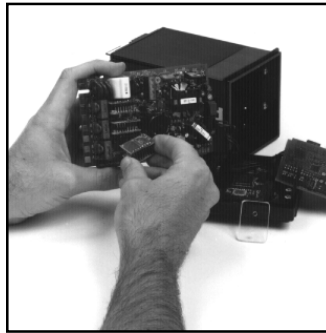
**6. To change module 4:**

Output Module 4 (on the Option board) is also held in place by a tie wrap. Snip tie wrap to remove module as shown in *Photo 6*.

7. *Figure 4.3* shows a representation of an output module. Inspect the module(s) to make sure that the pins are straight.
8. To install any module, align its pins with the holes in the circuit board, and carefully insert the module in the socket. Press down on the module until it is firmly seated; refer to *Photo 8*.



**6. Snip Tie Wrap**



**8. Add/Change Module**

9. Replace tie wraps for all the modules (the Retention Plate and Output Module 4) with new ones before reassembling the controller.

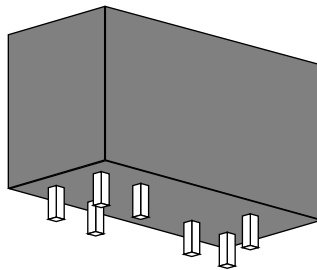
Failure to use the tie wraps may result in loosening of the module and eventual failure. All separately ordered modules come with a tie wrap.

**NOTE: For greatest accuracy, calibrate all milliamp modules added for retransmission as per the instructions in Appendix 2.**

10. Rejoin the circuit boards by aligning the pins of their connectors, then squeezing the board(s) together. Make sure that all three printed circuit boards are properly seated against one another; check along side edges for gaps. Make sure the cable assemblies are not pinched.
11. To reattach the board assembly to the front face assembly, align the boards (with the open area on top) into the slots of the front face assembly. The clips should snap into place.
12. To reassemble the controller, properly orient the chassis with board opening on top. Align the circuit boards into the grooves on the top and bottom of the case. Press firmly on the front face assembly until the chassis is all the way into the case.

If it is difficult to slide the chassis in all the way, make sure the screws have been removed (they can block proper alignment), and that the chassis is properly oriented.

- Carefully insert and align screws. Tighten them until the bezel is seated firmly against the gasket. **Do not overtighten.**



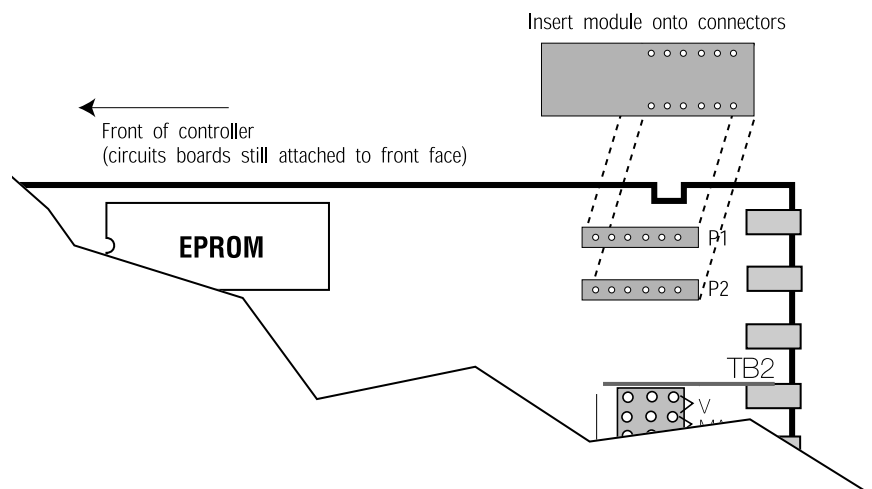
**Fig. 4.3 Representation of Module**

## SPECIAL COMMUNICATIONS MODULE

A special communications module is available for the DPC535; see order code in Chapter 1 for details.

Equipment needed:      Wrist grounding strap  
                                     Phillips screwdriver (#2)  
                                     Small flat blade screwdriver

- Before installing the communications module, set up the hardware wiring for the application. See Chapter 4 for details.
- With power off, loosen two front screws, and remove them.



**Fig. 4.4 Install Communications Module onto Microcontroller Board**

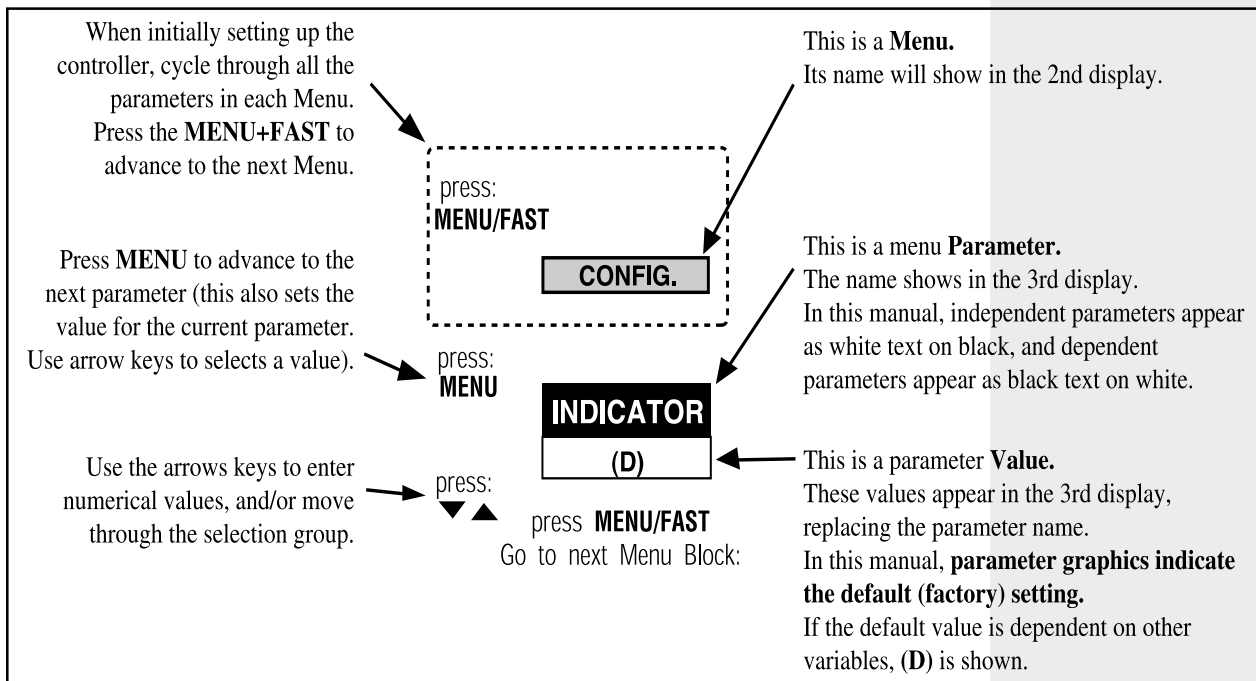
3. Slide the chassis out of the case by pulling firmly on the bezel. Do not detach the board assembly from the front face of the controller.
4. Orient the Communications Module as shown, and attach it to Connectors P1 and P2 as shown in *Figure 4.4*.
5. To reassemble the controller, properly orient the chassis with board opening on top. Align the circuit boards into the grooves on the top and bottom of the case. Press firmly on the front face assembly until the chassis is all the way into the case.

If it is difficult to slide the chassis in all the way, make sure the screws have been removed (they can block proper alignment), and that the chassis is properly oriented.

6. Carefully insert and align screws. Tighten them until the bezel is seated firmly against the gasket. **Do not overtighten.**

## 5. SOFTWARE CONFIGURATION

The software configuration menus of the DPC 535 contain user-selected variables that define the action of the controller. Read through this section before making any parameter adjustments to the controller.



**Fig. 5.1 Menu Flowchart for Set Up**

**CAUTION!**

All software changes occur in real time; always perform set up functions under manual operation.

**NOTE:**

For information about the Tuning menu/mode, refer to Chapter 6. For more information about set up parameters and DPC 535 applications, refer to Chapter 7.

**MENUS**

In Set Up mode, there are 13 sets of options that control different aspects of DPC 535 operation; in Tuning mode, there is one. Each set of options is called a **menu**. When traversing the two modes, the menu names appear in the 2nd display.

- CONFIG** Mode selection and input/output hardware assignments
  - PV1 INPUT** 1st process variable input options
  - PV2 INPUT** 2nd process variable input options
  - CUST. LINR.** Linearization curve options for PV1 input.
  - CONTROL** Control options
  - ALARMS** Alarm options
  - RETRANS.** Retransmission output options
  - SELF TUNE** Self tune algorithm options
  - SPECIAL** Special feature options
  - SECURITY** Security functions
  - SER.COMM.** Serial Communications options (requires comm. board)
- and
- TUNING** Tuning parameters configuration (see Chapter 6)

## PARAMETERS

Within each menu are **parameters** for particular control functions. Select values for each parameter depending on the specific application. Use the MENU key to access parameters for a particular menu; the parameter name will replace the menu name in the 2nd display, and the parameter value will show in the 3rd display.

This chapter outlines **all** the available parameters for the DPC 535. Some parameters are **independent** of any special configuration, and others are **dependent** on the individual configuration. This manual displays these two types of parameters differently; refer to Figure 5.2. A special feature of the DPC 535, called **Smart Menus**, determines the correct parameters to display for the specific configuration, so not all the listed parameters will appear.

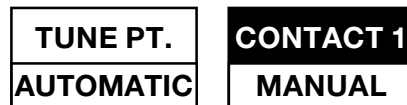


Fig. 5.2 Independent vs. Dependent Parameters

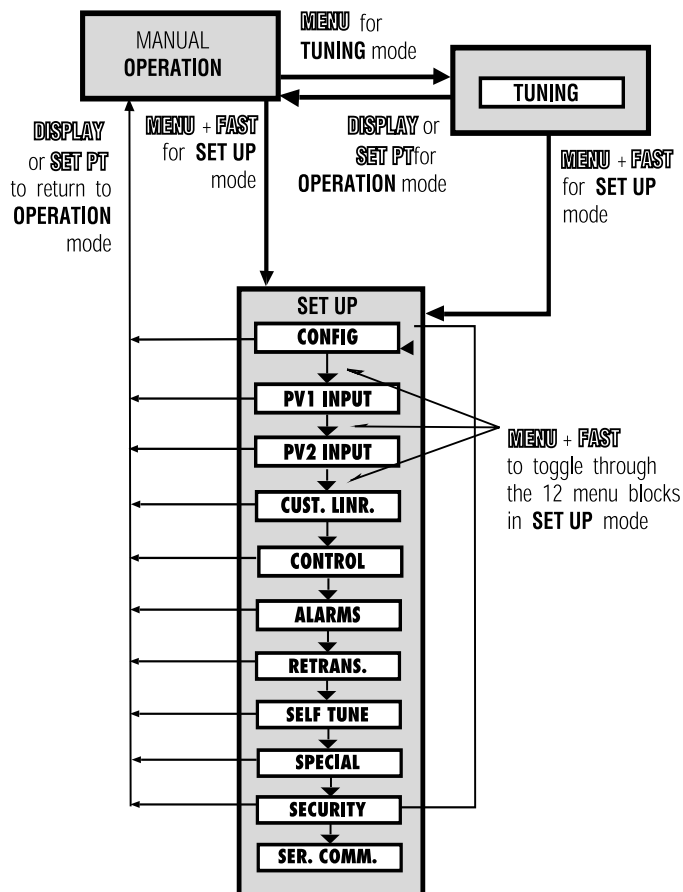


Fig. 5.3 Configuration Flowchart



## CONFIGURATION AND OPERATION

Figure 5.3 shows the relationships among the different modes of the 535 and the configuration menus:

- SET UP menus can only be accessed from manual control. To transfer the DPC 535 from automatic to manual control, press **MANUAL**.
- To access the SET UP menus, hold down **FAST** and press **MENU**. The **MENU** key will illuminate; and CONFIG will appear in the 2nd display.
- To access the parameters for a particular menu, press **MENU**.
- To select a parameter value, use **▲** and **▼**. Press **MENU** to advance to the next parameter, or **FAST+MENU** to advance to the next menu.
- To advance to the next menu, press **FAST+MENU**.
- TUNING mode (and the TUNING menu) can be accessed from either automatic or manual control. To access the tuning menu, press **MENU**.
- To return controller to manual control, press **DISPLAY** or **SET PT**.

A key to these functions (as shown below) appears at the bottom of every page in the menu section of this chapter.

Access Set Up ≡FAST+ MENU	Return to Operation DIS-	Next menu ≡FAST+ MENU	Next parameter MENU	Next parameter ▲ ▼	Next value MENU	Access Tuning DIS-
------------------------------	-----------------------------	--------------------------	------------------------	-----------------------	--------------------	-----------------------

## WHERE TO GO NEXT

- For information about all the software menus and parameters, continue reading this chapter. Refer to Appendix D for a quick-reference flowchart of all menus and parameters.
- For information about the installed options on the DPC535, compare the product label on top of the controller to the order code in Chapter 1.
- To mount the controller and configure the wiring of the DPC535 for inputs and outputs, see Chapter 3.
- To alter the output module and jumper configuration of the controller, see Chapter 4.
- For more information about applications for the DPC535, see Chapter 6.
- For more information about the Tuning function of the DPC535, see Chapter 7.

## TEXT FORMATTING IN THIS MANUAL

<u>Feature</u>	<u>Format</u>
<b>KEYS</b>	<b>SET PT</b> <b>DISPLAY</b>
	or
	<div style="display: inline-block; border: 1px solid black; padding: 2px 10px; margin: 0 10px;">SET PT</div> <div style="display: inline-block; border: 1px solid black; padding: 2px 10px;">DISPLAY</div>
<b>ICONS</b>	OUT, ALM
<b>MENUS</b>	CONFIG., TUNING,
<b>PARAMETERS</b>	CYCLE TM:1, MIN.OUT2
<b>PARAMETER VALUES</b>	OFF, SETPOINT, LAST OUT.
<b>DISPLAY MESSAGES</b>	TOO HOT, OUT%,

## SOFTWARE MENUS AND PARAMETERS

### CONFIG.

#### 1. CTRL. TYPE

Defines the type of control output(s).

- D STANDARD**            **Standard control output, no special algorithms**
- **POS. PROP.**            **Position proportioning control output**
- **STAGED**                **Staged outputs**
- **DUPLEX**                **Duplex outputs**

#### 2. LINE FREQ

Defines the power source frequency.

- **50 HZ**

**D 60 HZ**

CONFIG.

CTRL. TYPE  
STANDARD

LINE FREQ  
60 Hz

Access Set Up 	Return to Operation 	Next menu 	Next parameter 	Next value 	Access Tuning 
-------------------	-------------------------	---------------	--------------------	----------------	-------------------

**PV SOURCE**

**PV1**

**NOTE:**

PV1 and PV2 can be of different types and different range.

**OUTPUT 2**

**OFF**

**OUTPUT 3**

**OFF**

**3. PV SOURCE**

Defines how the PV input is derived from PV1 and PV2.

- |          |                   |  |
|----------|-------------------|--|
| <b>D</b> | <b>PVI</b>        | <b>Use PVI</b>                               |
| •        | <b>I/2:SWITCH</b> | <b>Use PVI until contact/com selects PV2</b> |
| •        | <b>I/2:BACKUP</b> | <b>Use PV2 if PVI is broken</b>              |
| •        | <b>PVI-PV2</b>    | <b>Use PVI-PV2</b>                           |
| •        | <b>PVI+PV2</b>    | <b>Use PVI+PV2</b>                           |
| •        | <b>AVG. PV</b>    | <b>Use the average of PVI and PV2</b>        |
| •        | <b>HI SELECT</b>  | <b>Use PVI or PV2 (whichever is greater)</b> |
| •        | <b>LO SELECT</b>  | <b>Use PVI or PV2 (whichever is less)</b>    |

**4. OUTPUT 2**

Defines the function of the second output.

- |          |                    |  |
|----------|--------------------|--|
| •        | <b>ALM.RLY:ON</b>  |  |
| •        | <b>ALM.RLY:OFF</b> |  |
| •        | <b>RETRANS.</b>    | <b>Retransmission</b>                                |
| •        | <b>COMM. ONLY</b>  | <b>Output addressable only through communication</b> |
| <b>D</b> | <b>OFF</b>         | <b>Completely deactivates the output</b>             |

**5. OUTPUT 3**

Defines the function of the third output.

- |          |                    |   |
|----------|--------------------|---|
| •        | <b>ALM.RLY:ON</b>  |   |
| •        | <b>ALM.RLY:OFF</b> |   |
| •        | <b>RETRANS.</b>    | <b>Retransmission</b>                                 |
| •        | <b>COMM. ONLY</b>  | <b>Output addressable only through communications</b> |
| <b>D</b> | <b>OFF</b>         | <b>Completely deactivates the output</b>              |

Access Set Up ≡FAST+ MENU	Return to Operation DISPLAY	Next menu ≡FAST+ MENU	Next parameter MENU	Next value ▲ ▼	Access Tuning MENU DISPLAY
------------------------------	--------------------------------	--------------------------	------------------------	-------------------	-------------------------------

## 6. OUTPUT 4

Defines the function of the fourth output.

- **ALM.RLY:ON**
- **ALM.RLY:OFF**
- **RETRANS. Retransmission**
- **COMM. ONLY Output addressable only through communications**

**D OFF** Completely deactivates the output

## 7. ANLG. RNG.:1

Defines the output signal for the first output.

**D 4–20 mA**

- **0–20 mA**
- **20–4 mA**
- **20–0 mA**

## 8. ANLG. RNG.:2

Defines the output signal for the second output.

**D 4–20 mA**

- **0–20 mA**
- **20–4 mA**
- **20–0 mA**

## 9. ANLG. RNG.:3

Defines the output signal for the third output.

**D 4–20 mA**

- **0–20 mA**
- **20–4 mA**
- **20–0 mA**

## 10. ANLG. RNG.:4

Defines the output signal for the fourth output.

**D 4–20 mA**

- **0–20 mA**
- **20–4 mA**
- **20–0 mA**

## 11. LOOP NAME

A 9-character message associated with the loop. The first character of the 3rd display will be flashing. To enter message, press ▲ and ▼ keys to scroll through character set. Press FAST key to enter the selection and move to next digit. Press MENU key to advance to the next parameter.

**D LOOP ONE**

**OUTPUT 4**

**OFF**

**ANLG.RNG.:1**

**4-20 mA**

**ANLG.RNG.:2**

**4-20mA**

**ANLG.RNG.:3**

**4-20mA**

**ANLG.RNG.:4**

**4-20mA**

**LOOP NAME**

**LOOP ONE**

**PV INPUT**

**PV1 TYPE**

**J T/C**

**CAUTION!**

Set parameter values in the presented order dependent parameters are dynamically related and changing values of one can alter the value of another.

For example, if SP LO LIM. is set to 0, and then thermocouple type is changed to B T/C, the SP LO LIM. value will change to 104° (the low limit of a type B thermocouple).

**DEG. F/C/K**

**FAHR**

**DECIMAL**

**XXXXX**

**PVI INPUT**

**1. PVI TYPE**

Specifies the particular sensor range or input range for PV1.

<u>T/C</u>	<u>RTD</u>	<u>VOLTAGE</u>	<u>CURRENT (mA)</u>
<b>D J T/C</b>	<b>D DIN RTD</b>	<b>D 1-5 V</b>	<b>D 4-20mA</b>
• <b>E T/C</b>	• <b>JIS RTD</b>	• <b>0-5 V</b>	• <b>0-20mA</b>
• <b>K T/C</b>	• <b>SAMA RTD</b>	• <b>0-10 mV</b>	
• <b>B T/C</b>		• <b>0-30 mV</b>	
• <b>N T/C</b>		• <b>0-60 mV</b>	
• <b>R T/C</b>		• <b>0-100 mV</b>	
• <b>S T/C</b>		• <b>+/- 25 mV</b>	
• <b>T T/C</b>		<u>STRAIN GAGE</u>	
• <b>W T/C</b>		• <b>3.33 mV/V</b>	
• <b>W5 T/C</b>			
• <b>PLAT.II T/C</b>			

**2. DEG. F/C/K**

Selects the PV1 temperature units if using a thermocouple or RTD.

- D FAHR.**
- **CELSIUS**
- **KELVIN**

**3. DECIMAL**

Specifies the PV1 decimal point position.

- D XXXXX**
- **XXXX.X**
- **XXX.XX**
- **XX.XXX**
- **X.XXXX**

Access Set Up ≡FAST+ MENU	Return to Operation DISPLAY	Next menu ≡FAST+ MENU	Next parameter MENU	Next value ▲ ▼	Access Tuning MENU DISPLAY
------------------------------	--------------------------------	--------------------------	------------------------	-------------------	-------------------------------

#### 4. LINEARIZE

Specifies if the PV1 input is to be linearized. NOTE: T/C's and RTD's are automatically linearized.

**D NONE**

- **SQR. ROOT** Square root linearization is activated.
- **CUSTOM** 15-point custom linearization curve is activated.

<b>LINEARIZE</b>
<b>NONE</b>

#### 5. LOW RANGE

Specifies the engineering unit value corresponding to the lowest PV1 input value, e.g. 4 mA.

**R -9999 to 99999** Max. is HI RANGE

**D** Dependent on the input selection

<b>LOW RANGE</b>
<b>(D)</b>

#### 6. HI RANGE

Specifies the engineering unit value corresponding to the highest PV1 input value, e.g., 20mA.

**R -9999 to 99999** Min. is LOW RANGE

**D** Dependent on the input selection

<b>HI RANGE</b>
<b>(D)</b>

#### 7. SP LO LIM.

Defines the lowest setpoint value that can be entered from the front panel only.

**R -9999 to 99999** Max. is SP HI LIM. Min. is LOW RANGE

**D** Dependent on the LOW RANGE value.

<b>SP LO LIM.</b>
<b>(D)</b>

#### 8. SP HI LIM.

Defines the highest setpoint value that can be entered from the front panel only.

**R -9999 to 99999** Min. is SP LO. LIM. Maximum is HI RANGE

**D** Dependent on HI RANGE

<b>SP HI LIM.</b>
<b>(D)</b>

Access Set Up <b>[FAST+] MENU</b>	Return to Operation <b>DISPLAY</b>	Next menu <b>[FAST+] MENU</b>	Next parameter <b>MENU</b>	Next value <b>▲ ▼</b>	Access Tuning <b>MENU DISPLAY</b>
--------------------------------------	---------------------------------------	----------------------------------	-------------------------------	--------------------------	--------------------------------------

**SP RAMP**

**OFF**

**FILTER**

**0**

**OFFSET**

**0**

**GAIN**

**1.000**

**RESTORE**

**LAST MODE**

**SHUNT %**

**80%**

**R-CAL**

**NO**

**SET ZERO**

**NO**

**SET SPAN**

**NO**

**9. SP RAMP**

Defines the rate of change for setpoint changes.

**D OFF Deactivates this function**

**R 1 to 99999 units per hour**

**10. FILTER**

Specifies the setting for the low pass PV1 input filter.

**R 0 to 120 seconds**

**D 0 seconds**

**11. OFFSET**

Defines the offset to PV1 in engineering units.

**R -9999 to 99999**

**D 0**

**12. GAIN**

Defines the gain to PV1.

**R 0.100 to 10.000**

**D 1.000**

**13. RESTORE**

Defines the control mode when a broken PV1 signal is restored.

**D LAST MODE**

- **MANUAL**
- **AUTOMATIC**

**14. SHUNT %**

Defines.....Explain this function in your industry's terms

**R 40% to 100%**

**D 80%**

**15. R-CAL**

Determines whether shunt resistance is used or not

**D No**

- **Yes**

**16. SET ZERO**

Activates set zero function.

To initiate the Set Zero function, press the ▲ or ▼ keys. Confirm by pressing **ACK** within five seconds

- **No**

**17. SET SPAN**

Activates set span function.

To initiate the Set Span function, press the ▲ or ▼ keys. Confirm by pressing **ACK** within five seconds

- **No**

## PV2 INPUT

### 1. PV2 SETUP

Defines function of PV2

- **D SAME.AS.PV1** All PV2 parameters are set to the same as PVI (no further parameters will appear) Note: When differential strain gage is selected, PVI and PV2 must be the same.

### 2. PV2 TYPE

Selects the particular sensor or input range for PV2

<u>T/C</u>	<u>RTD</u>	<u>VOLTAGE</u>	<u>CURRENT (mA)</u>
• J T/C	<b>D DIN RTD</b>	<b>D 1-5 V</b>	<b>D 4-20mA</b>
• E T/C	• JIS RTD	• 0-5 V	• 0-20mA
• K T/C	• SAMA RTD	• 0-10 mV	
• B T/C		• 0-30 mV	
• N T/C		• 0-60 mV	
• R T/C		• 0-100 mV	
• S T/C		• +/- 25 mV	
• T T/C		<u>STRAIN GAGE</u>	
• W T/C		• 3.33 mV/V	
• W5 T/C			
• PLAT.II T/C			

### 3. DECIMAL

Specifies the PV2 decimal point position.

- D XXXXX**
- XXXX.X
- XXX.XX
- XX.XXX
- X.XXXX

### 4. LINEARIZE

Specifies if the PV2 input is to be linearized. Thermocouples and RTD's are automatically linearized.

- D NONE**
- **SQR. ROOT** Square root linearization is activated.

### 5. LOW RANGE

Specifies the engineering unit value corresponding to the lowest PV2 input value, e.g. 4 mA.

- R -9999 to 99999** Max. is HI RANGE
- D** Dependent on the input selection

PV2 INPUT

PV2 SETUP  
SAME.AS.PV1

PV2 TYPE  
J/TC

DECIMAL  
XXXXX

LINEARIZE  
NONE

LOW RANGE  
(D)



**HI RANGE****(D)****FILTER****0****OFFSET****0****GAIN****1.000****RESTORE****LAST MODE****NOTE:**

Menu boxes for PV2  
are the same as for  
PV1.

**6. HI RANGE**

Specifies the engineering unit value corresponding to the highest PV2 input value, e.g. 20 mA.

**R** -9999 to 99999     **Min. is LOW RANGE**

**D** **Dependent on the input selection**

**7. FILTER**

Setting for the low pass PV2 input filter.

**R** 0 to 120 seconds

**D** 0 seconds

**8. OFFSET**

Defines the offset to PV2 in engineering units.

**R** -9999 to 99999

**D** 0

**9. GAIN**

Defines the gain for PV2.

**R** 0.100 to 10.000

**D** 1.000

**10. RESTORE**

Defines the control mode when a broken PV2 signal is restored.

**D** **LAST MODE**

- **MANUAL**
- **AUTOMATIC**

**11. SHUNT %**

Defines.....Explain this function in your industry's terms

**R** 40% to 100%

**D** 80%

**12. R-CAL**

Determines whether shunt resistance is used or not

**D** **No**

- **Yes**

**13. SET ZERO**

Activates set zero function.

To initiate the Set Zero function, press the ▲ or ▼ keys. Confirm by pressing **ACK** within five seconds

- **No**

**14. SET SPAN**

Activates set span function.

To initiate the Set Span function, press the ▲ or ▼ keys. Confirm by pressing **ACK** within five seconds

- **No**

## CUST. LINR.

Defines a custom linearization curve for PV1, if selected. Points 1 and 15 are fixed to the low and high end of the input range and require only setting a corresponding PV value. Points 2 through 14 (the Xth points) require setting both the input and PV values.

It is not necessary to use all 15 points. Whenever the **XTH INPUT** becomes the high end of the range, that will be the last point in the linearization table.

### 1. 1ST. INPUT

Specifies the input signal corresponding to the first point.

**D** The low end of the appropriate input range (e.g. 4.00 mA)

### 2. 1ST. PV

Specifies the engineering unit value corresponding to the first point.

**R** -9999 to 99999

**D** 0

### 3. XTH. INPUT

Specifies the input signal corresponding to the XTH point (X is 2 to 14).

**R** Any value greater than the first input

**D** The low end of the appropriate input range (e.g. 4.00 mA)

### 4. XTH. PV

Specifies the unit value corresponding to the XTH point (X is 2 to 14).

**R** -9999 to 99999

**D** 0

### 5. 15TH. INPT.

Specifies the input signal corresponding to the 15th point.

**R** -9999 to 99999 Minimum is [XTH-1] INPUT

**D** The high end of the appropriate input range (e.g. 20.00 mA)

### 6. 15TH. PV

Specifies the engineering unit value corresponding to the 15th point.

**R** -9999 to 99999

**D** 0

CUST. LINR.

1ST. INPUT

(D)

1ST. PV

0

XTH INPUT

(D)

XTH PV

0

15TH INPT.

(D)

15TH PV

0

**CONTROL**

**ALGORITHM**

**PID**

**D. SOURCE**

**PV**

**ACTION:1**

**REVERSE**

**PV BREAK**

**(D)**

**LOW OUT**

**0**

**HIGH OUT**

**100**

**ACTION: 2**

**DIRECT**

**CONTROL**

For configuring the choices for the control algorithm

**1. ALGORITHM**

Defines the type of control algorithm.

**D PID**

- **PI**
- **PD**
- **P**
- **ON/OFF**
- **PID:ON/OFF**

**For Duplex applications using PID for the first output and on/off for the second output**

**2. D. SOURCE**

Selects the variable for the derivative action.

**D PV**

**Derivative term will not react when setpoint changes**

- **DEVIATION**

**Derivative term will react when setpoint changes**

**3. ACTION:1**

Defines the action of the first control output.

- **DIRECT**

**D REVERSE**

**4. PV BREAK**

Defines the manual output level if the process variable input is lost. Choose values based on the process type.

Standard Control

- **-5 to 105%**
- D 0**

On/Off Control

- **ON**
- D OFF**

Velocity Prop Control

- **CW**
- **CCW**
- D OUTS. OFF**

**5. LOW OUT**

Defines the lowest output value that can be achieved in automatic control.

**R 0 – 100% Max is HIGH OUT**

**D 0%**

**6. HIGH OUT**

Defines the highest output value that can be achieved in automatic control.

**R 0 – 100% Min is LOW OUT**

**D 100%**

**7. ACTION:2**

Defines the action of the second control output.

**D DIRECT**

- **REVERSE**

### 8. P.P. TYPE

Defines the type of position proportioning algorithm. Choose values based on the process.

Feedback option installed

- D SLIDEWIRE
- VELOCITY

Feedback option not installed

- SLIDEWIRE
- D VELOCITY

## ALARMS

### 1. ALM. TYPE:I

Defines the type of alarm for alarm 1.

- HIGH ALRM.
- LOW ALARM
- HIGH/LOW Separate High & Low alarm setpoints in one alarm
- BAND
- DEVIATION
- MANUAL Causes an alarm when in manual control
- RATE Selects a rate-of-change alarm
- D OFF Deactivates the first alarm

### 2. ALM. SRC:I

Selects the source of the value being monitored by HIGH, LOW or HIGH/LOW alarm 1.

- D PV
- SP
- RAMP SP
- DEVIATION
- OUTPUT
- PV2

### 3. ALARM SP:I

Specifies the alarm set point for alarm 1 (except HIGH/LOW)

For HIGH or LOW alarms:

If ALM.SRC.:I = OUTPUT

R 0.0% to 100.0%

D 0.0%

For BAND alarms:

R I to 99999

D 0

For DEVIATION or RATE alarms:

R -9999 to 99999

D 0

If ALM.SRC.:I = any other type

R LOW RANGE to HI RANGE

D 0

P.P. TYPE

(D)

ALARMS

ALM. TYPE:1

OFF

ALM. SRC:1

PV

ALARM SP:1

0.0%

**HIGH SP:1**

**0.0%**

**LOW SP:1**

**0.0%**

**DEADBAND:1**

**2**

**ALM.:1 OUT**

**NONE**

**LATCHING:1**

**NONE**

**4A.HIGH SP:I**

Specifies the high alarm set point for alarm 1 of type HIGH/LOW.

If **ALM.SRC.:I** = OUTPUT      If **ALM.SRC.:I** = any other type

**R 0.0% to 100.0%**                      **R LOW RANGE to HI RANGE**

**D 0.0%**                                      **D 0**

**4B.LOW SP:I**

Specifies the low alarm set point for alarm 1 of type HIGH/LOW.

If **ALM.SRC.:I** = OUTPUT      If **ALM.SRC.:I** = any other type

**R 0.0% to 100.0%**                      **R LOW RANGE to HI RANGE**

**D 0.0%**                                      **D 0**

**5. DEADBAND:I**

Defines the deadband for alarm 1.

If **ALM.SRC.:I** = OUTPUT      If **ALM.SRC.:I** = any other type

**R 0.1% to 100.0%**                      **R 1 to 99999**

**D 2**    **D 2**

**6. ALM.:I OUT.**

Selects the output number for alarm 1.

**D NONE**

- 2
- 3
- 4

**7. LATCHING:I**

Defines the latching sequence of alarm 1.

**D LATCH**

- NO LATCH

## 8. ACK.:1

Defines whether alarm 1 may be acknowledged.

- D ENABLED** Allows the alarm to be acknowledged
- **DISABLED** Prevents the alarm from being acknowledged while in alarm condition

## 9. POWER UP:1

Defines how alarm 1 will be treated on power up.

- D NORMAL** Alarm depends on process variable
- **ALARM** Always power up in alarm regardless of PV
  - **DELAYED** Must leave alarm condition and reenter before activating the alarm

## 10. MESSAGE:1

A 9-character message associated with alarm 1. To enter message: The first character of third display will be flashing. Press the ▲ and ▼ keys to scroll through the character set. Press **FAST** key to advance to subsequent characters. Press the **MENU** to advance to next parameter.

- D ALARM 1.**

## 11. ALM. TYPE:2

Defines the type of alarm for alarm 2.

- **HIGH ALRM.**
  - **LOW ALARM**
  - **HIGH/LOW** Separate High & Low alarm setpoints in one alarm
  - **BAND**
  - **DEVIATION**
  - **MANUAL** Causes an alarm when in manual control
  - **RATE** Selects a rate-of-change alarm
- D OFF** Deactivates the first alarm

**ACK.:1**

**ENABLED**

**POWER UP:1**

**NORMAL**

**MESSAGE:1**

**ALARM 1**

**ALM. TYPE:2**

**OFF**

**ALM.SRC.:2**

**PV**

**ALARM SP:2**

**(D)**

**HIGH SP:2**

**0.0%**

**LOW SP:2**

**0.0%**

## 12. ALM. SRC:2

Selects the source of the value being monitored by HIGH, LOW or HIGH/LOW alarm 2.

- D PV**
- **SP**
  - **RAMP SP**
  - **DEVIATION**
  - **OUTPUT**
  - **PV2**

## 13. ALARM SP:2

Specifies the alarm set point for alarm 2 (except HIGH/LOW)

For HIGH or LOW alarms:

If **ALM.SRC.:2** = OUTPUT

**R 0.0% to 100.0%**

**D 0.0%**

If **ALM.SRC.:2** = any other type

**R LOW RANGE to HI RANGE**

**D 0**

For **BAND** alarms:

**R 1 to 99999**

**D 0**

For **DEVIATION** or **RATE** alarms:

**R -9999 to 99999**

**D 0**

## 14A. HIGH SP:2

Specifies the high alarm set point for alarm 2 of type HIGH/LOW.

If **ALM.SRC.:2** = OUTPUT

**R 0.0% to 100.0%**

**D 0.0%**

If **ALM.SRC.:2** = any other type

**R LOW RANGE to HI RANGE**

**D 0**

## 14B. LOW SP:2

Specifies the low alarm set point for alarm 2 of type HIGH/LOW.

If **ALM.SRC.:2** = OUTPUT

**R 0.0% to 100.0%**

**D 0.0%**

If **ALM.SRC.:2** = any other type

**R LOW RANGE to HI RANGE**

**D 0**

### 15. DEADBAND:2

Defines the deadband for alarm 2.

If **ALM.SRC.:2** = OUTPUT      If **ALM.SRC.:2** = any other type

**R 0.1% to 100.0%**

**R 1 to 99999**

**D 2**

**D 2**

### 16. ALM.:2 OUT.

Selects the output number for alarm 2.

**D NONE**

- 2
- 3
- 4

### 17. LATCHING:2

Defines the latching sequence of alarm 2.

**D LATCH**

- NO LATCH

### 18. ACK.:2

Defines whether alarm 2 may be acknowledged.

**D ENABLED**      Allows the alarm to be acknowledged

- **DISABLED**      Prevents the alarm from being acknowledged while in alarm condition

### 19. POWER UP:2

Defines how alarm 2 will be treated on power up.

**D NORMAL**      Alarm depends on process variable

- **ALARM**      Always power up in alarm regardless of process variable
- **DELAYED**      Must leave alarm condition and reenter before activating the alarm

### 20. MESSAGE:2

A 9-character message associated with alarm 2. To enter message: The first character of third display will be flashing. Press the ▲ and ▼ keys to scroll through the character set. Press **FAST** key to advance to subsequent characters. Press **MENU** to advance to next parameter.

**D ALARM 2.**

**DEADBAND:2**

**2**

**ALM.:2 OUT.**

**NONE**

**LATCHING:2**

**LATCH**

**ACK.:2**

**ENABLED**

**POWER UP:2**

**NORMAL**

**MESSAGE:2**

**ALARM 2**



**FAULT****OFF****OUTPUT****NO ACTION****RATE TIME****5****RETRANS.****TYPE:2****PV****LO RANGE:2****(D)**

## 21. FAULT

Defines whether either of the alarm relays will trip if a fault condition (lost process variable) is detected. Only appears if at least one alarm relay is installed.

**D OFF**

- **ALARM 1**
- **ALARM 2**

## 22. OUTPUT

Defines whether a rate-of-change alarm is interpreted as a lost or broken process variable (causing a trip to manual output).

- **P.V. BREAK**

**D NO ACTION**

## 23. RATE TIME

Defines the time period over which a rate-of-change alarm condition is determined.

**R 1 to 3600 seconds****D 5 seconds**

---

## RETRANS.

### 1. TYPE:2

Defines what is to be retransmitted for output 2

- D PV** This refers to the linearized process variable
- **SETPOINT** This is the target setpoint
  - **RAMP SP** This is the ramping, or actual setpoint, when the setpoint is ramping
  - **CTRL. OUT** This is the control output value

### 2. LOW RANGE:2

Defines the low end of the range for output 2 in engineering units. Does not appear for type CTRL.OUT.

**R -9999 to 99999****D Dependent on the process variable range**

### 3. HI RANGE:2

Defines the high end of the range for output 2 in engineering units.  
Does not appear for type CTRL.OUT.

**R** -9999 to 99999

**D** Dependent on the process variable range

### 4. TYPE:3

Defines what is to be retransmitted for output 3

**D** **PV** This refers to the linearized process variable

- **SETPOINT** This is the target setpoint
- **RAMP SP** This is the ramping, or actual setpoint, when the setpoint is ramping
- **CTRL. OUT** This is the control output value

### 5. LOW RANGE:3

Defines the low end of the range for output 3 in engineering units.  
Does not appear for type CTRL.OUT.

**R** -9999 to 99999

**D** Dependent on the process variable range

### 6. HI RANGE:3

Defines the high end of the range for output 3 in engineering units.  
Does not appear for type CTRL.OUT.

**R** -9999 to 99999

**D** Dependent on the process variable range

### 7. TYPE:4

Defines what is to be retransmitted for output 4

**D** **PV** This refers to the linearized process variable

- **SETPOINT** This is the target setpoint
- **RAMP SP** This is the ramping, or actual setpoint, when the setpoint is ramping
- **CTRL. OUT** This is the control output value

**HI RANGE:2**

**(D)**

**TYPE:3**

**PV**

**LO RANGE:3**

**(D)**

**HI RANGE:3**

**(D)**

**TYPE:4**

**PV**

**LO RANGE:4****(D)****HI RANGE:4****(D)****SELF TUNE****TYPE****DISABLED****PRETUNE****TYPE 1****TUNE PT.****AUTOMATIC****OUT.STEP****10.0****50****8. LOW RANGE:4**

Defines the low end of the range for output 4 in engineering units. Does not appear for type CTRL.OUT.

**R** -9999 to 99999

**D** Dependent on the process variable range

**9. HI RANGE:4**

Defines the high end of the range for output 4 in engineering units. Does not appear for type CTRL.OUT.

**R** -9999 to 99999

**D** Dependent on the process variable range

**SELF TUNE****1. TYPE**

Defines the type of self tuning algorithm that is available.

- **PRETUNE** Allows the operator to initiate Pretune only
- **ADAPTIVE** Allows the operator to initiate Adaptive Tune only
- **BOTH** Allows the operator to initiate both Pretune and Adaptive Tune

**D** **DISABLED** Both Pretune and Adaptive Tune are disabled

**2. PRETUNE**

Defines the type of pretune algorithm that is available.

**D** **TYPE 1** Normally used with slower thermal processes

- **TYPE 2** Normally used with faster fluid or pressure processes

- **TYPE 3** Normally used with level control applications

**3. TUNE PT.**

Defines the PV value at which the output will switch off during a TYPE 1 pretune. Helps prevent overshoot.

**R** Any value in PV input range

**D** **AUTOMATIC** (Controller defines this point, low end for Automatic)

**4. OUT. STEP**

Defines the output step size in absolute percent during a TYPE 2 or TYPE 3 pretune.

**R** -50% to 50.0%

**D** 10.0%

## 5. LOW LIMIT

Defines the lower most limit the process variable can reach during pretune before aborting.

- R Any value in the process variable range**
- D Dependent on the process variable range**

## 6. HI LIMIT

Defines the upper most limit the process variable can reach during pretune before aborting.

- R Any value in the process variable range**
- D Dependent on the process variable range**

## 7. TIMEOUT

This defines the execution time limit for pretune before aborting.

- R 8 to 1500 minutes**
- D 1500 minutes**

## 8. MODE

Defines the control mode after pretune is completed or aborted.

- MANUAL**
- D AUTOMATIC**

## 9. NOISE BND.

Defines the noise band to be used by the adaptive tuning algorithm.

- R 0.1% to 10% of the process variable range**
- D 0.2%**

## 10. RESP. TIME

Defines response time to be used by the adaptive tuning algorithm.

- R 10 to 32000 seconds**
- D 7200 seconds**

**LOW LIMIT**

**(D)**

**HI LIMIT**

**(D)**

**TIMEOUT**

**1500**

**MODE**

**AUTOMATIC**

**NOISE BND.**

**0.2**

**RESP. TIME**

**60**

**DEAD TIME**

**0.1**

**SPECIAL**

**AUTO. TRIP**

**OFF**

**TRIP DEV.**

**(D)**

**DES. OUTPT.**

**(D)**

**POWER UP**

**LAST MODE**

**11. DEAD TIME**

Defines the amount of time required for process to begin to respond to an output change (used by POWERBACK algorithm).

- R 0.1 seconds to 7200.0 seconds**  
**D 0.1 seconds**

**SPECIAL**

**1. AUTO. TRIP**

Defines the condition under which the DPC535 will automatically trip to automatic control from manual control upon start up.

- D OFF Deactivates this function**
- **RISING PV** Will trip when a rising process variable is within the specified deviation from the setpoint
  - **FALLNG. PV** Will trip when a falling process variable is within the specified deviation from the setpoint

**2. TRIP DEV.**

Defines the deviation from setpoint at which the controller will trip to automatic.

- |                                   |                                    |
|-----------------------------------|------------------------------------|
| For <b>AUTO. TRIP = RISING PV</b> | For <b>AUTO. TRIP = FALLING PV</b> |
| <b>R -99999 to 0</b>              | <b>R 0 to 99999</b>                |
| <b>D 0</b>                        | <b>D 0</b>                         |

**3. DES. OUTPT.**

If a digital input is defined to trip the controller to manual mode, this designates the output value after the trip. LAST OUT means that the output value will be equal to the last output value while in automatic. Choose values based on the process.

- |                         |                       |                              |
|-------------------------|-----------------------|------------------------------|
| <u>Standard Control</u> | <u>On/Off Control</u> | <u>Velocity Prop Control</u> |
| • -5 to 105%            | • ON                  | • CW                         |
| <b>D LAST OUT</b>       | <b>D OFF</b>          | • CCW                        |
|                         |                       | <b>D OUTS. OFF</b>           |

**4. POWER UP**

Defines the control mode upon power up.

- D LAST MODE** Will power up in the same mode prior to power down
- **PRETUNE** Will Pretune on every power up. (Recommended for TYPE I pretune only.)
  - **MANUAL**
  - **AUTOMATIC**

### 5. PWR. UP:OUT.

Defines the output of the controller if powering up in manual mode. "LAST OUT" means that the output value will be equal to the last output value while in automatic. Choose values based on the process.

<u>Standard Control</u>	<u>On/Off Control</u>	<u>Velocity Prop Control</u>
• -5 to 105%	• ON	• CW
D LAST OUT	D OFF	• CCW
		D OUTS. OFF

### 6. PWR. UP:SP

Defines the setpoint upon power up.

- D LAST SP Powers up with the same setpoint (local or remote) that was active prior to power down
- LOCAL Powers up using primary local setpoint
  - REMOTE Powers up using remote setpoint, if available

### 7. NO. OF SP

Defines the number of local setpoints (up to 8) to be stored for selection by BCD (binary coded decimal), digital inputs, or front SET PT key.

- R 1 through 8  
D 1

---

## SECURITY

For configuring the security function.

### 1. SEC. CODE

Defines the security code temporarily unlocking the instrument.

- R -9999 to 99999  
D 0

### 2. SP ADJUST

Defines lockout status setpoint changes.

- D UNLOCKED  
• LOCKED

PWR. UP:OUT.  
(D)

PWR. UP:SP  
LAST SP

NO. OF SP  
1

SECURITY

SEC. CODE  
0

SP ADJUST  
UNLOCKED

**AUTO./MAN.**

**UNLOCKED**

**SP SELECT**

**UNLOCKED**

**ALARM ACK**

**UNLOCKED**

**TUNING**

**UNLOCKED**

**CONFIGURE**

**UNLOCKED**

**SER. COMM.**

**STATION**

**1**

### 3. **AUTO./MAN.**

Defines lockout status of the **MANUAL** key.

**D UNLOCKED**

- **LOCKED**

### 4. **SP SELECT**

Defines lockout status of the **SET PT** key.

**D UNLOCKED**

- **LOCKED**

### 5. **ALARM ACK.**

Defines lockout status of the **ACK** key.

**D UNLOCKED**

- **LOCKED**

### 6. **TUNING**

Defines lockout status of the tuning parameters.

**D UNLOCKED**

- **LOCKED**

### 7. **CONFIGURE**

Defines lockout status of the configuration parameters.

**D UNLOCKED**

- **LOCKED**

---

## **SER. COMM.**

### **I. STATION**

Defines the unit's station address.

**R 1 to 99**

- **OFF Disables the communications function**

**D 1**

## 2. BAUD RATE

Defines the baud rate.

- 1200 BPS
- 2400 BPS
- 4800 BPS
- D 9600 BPS
- 19200 BPS

## 3. CRC

Defines whether CRC (cyclic redundancy check) is being calculated.

- D YES
- NO

## 4. SHED TIME

Defines the time interval between communications activity before the controller determines that communications is lost ("sheds").

- R 1 to 512 seconds
- D OFF

## 5. SHED MODE

Defines the state of the controller if communications is lost ("sheds").

- D **LAST MODE** Remain in automatic or manual control (last mode before losing communications)
- **MANUAL** Trip to manual control
- **AUTOMATIC** Trip to automatic control

## 6. SHED OUT.

Defines the output if the unit sheds and trips to manual control. Choose values based on the process.

Standard Control

- -5 to 105%
- D LAST OUT

On/Off Control

- ON
- D OFF

Velocity Prop Control

- CW
- CCW
- D OUTS. OFF

**BAUD RATE**

**9600**

**CRC**

**YES**

**SHED TIME**

**OFF**

**SHED MODE**

**LAST MODE**

**SHED OUT.**

**(D)**



**SHED SP**

**LAST SP**

**DESIG. SP**

**(D)**

## **7. SHED SP**

Defines the setpoint status if communications is lost.

- D LAST SP** Continues to use setpoint that was active prior to losing communications
- **DESIG. SP** Goes to a designated setpoint value if communications is lost.

## **8. DESIG. SP**

Defines the value of the designated setpoint if communications is lost.

- R Any value in the process variable range**
- D Dependent on the process variable range**

## PARAMETER VALUE CHARTS

This section of value charts is provided for logging in the actual parameter values and selections for the process. It is recommended that these pages be photocopied so there will always be a master.

### CONFIG

Parameter	Description	Values
1 CTRL. TYPE	Defines fundamental controller Set Up	
2 LINE FREQ.	Defines the power source frequency	
3 PV SOURCE	Defines how PV input is derived from PV1 and PV2	
4 OUTPUT 2	Function of the second output	
5 OUTPUT 3	Function of the third output	
6 OUTPUT 4	Function of the fourth output	
7 ANLG.RNG.:1	Output signal for the first output	
8 ANLG.RNG.:2	Output signal for the second output	
9 ANLG.RNG.:3	Output signal for the third output	
10 ANLG.RNG.:4	Output signal for the fourth output	
11 LOOP NAME	Nine character message associated with control loop	

**PV1 INPUT**

Parameter	Description	Value
1 PV1 TYPE	PV1 sensor or range to be used	
2 DEG. F/C/K	PV1 temperature engineering unit	
3 DECIMAL	PV1 decimal point position	
4 LINEARIZE	Type of PV1 input linearization	
5 LOW RANGE	Engineering unit value for lowest PV1 input value	
6 HI RANGE	Engineering unit value for highest PV1 input value	
7 SP LO LIM.	Lowest setpoint value that can be entered	
8 SP HI LIM.	Highest setpoint value that can be entered	
9 SP RAMP	Rate of change for setpoint changes	
10 FILTER	Setting for the low pass PV1 input filter (in seconds)	
11 OFFSET	Offset to PV1 in engineering units	
12 GAIN	Gain to PV1	
13 RESTORE	Control mode when a broken PV1 is restored	
14 SHUNT	Set Shunt percentage to watch transducer	
15 R-CAL	Selects automatic calibration	
16 SET ZERO	Calibrates low end of span	
17 SET SPAN	Calibrates full span	

**PV2 INPUT**

Parameter	Description	Value
1 PV2 SETUP	Makes PV2 input parameters match PV1, or user definable.	
2 PV2 TYPE	PV2 sensor or range to be used	
3 DECIMAL	PV2 decimal point position	
4 LINEARIZE	Type of PV2 input linearization	
5 LOW RANGE	Engineering unit value for lowest PV2 input value	
6 HI RANGE	Engineering unit value for highest PV2 input value	
7 FILTER	Setting for the low pass PV2 input filter (in seconds)	
8 OFFSET	Offset to the PV2 in engineering units	
9 GAIN	Gain to PV2	
10 RESTORE	Control mode when a broken PV2 is restored	
11 SHUNT	Set Shunt percentage to watch transducer	
12 R-CAL	Selects automatic calibration	
13 SET ZERO	Calibrates low end of span	
14 SET SPAN	Calibrates full span	

## ALARMS

Parameter	Description	Value
1 ALM. TYPE:1	Type of alarm for alarm 1	
2 ALM. SRC.:1	Source of value monitored by <b>HIGH, LOW</b> or <b>HIGH/LOW</b> alarm 1	
3 ALARM SP:1	Alarm setpoint for alarm 1 (except for <b>HIGH/LOW</b> )	
4A HIGH SP:1	High alarm setpoint for <b>HIGH/LOW</b> alarm 1	
4A LOW SP:1	Low alarm setpoint for <b>HIGH/LOW</b> alarm 1	
5 DEADBAND:1	Deadband for alarm 1	
6 ALM.:1 OUT.	Output number for alarm 1	
7 LATCHING:1	Latching sequence for alarm 1	
8 ACK.:1	Whether alarm 1 may be acknowledged	
9 POWER UP:1	How alarm 1 will be treated upon power up	
10 MESSAGE:1	Nine character message associated with alarm 1	
11 ALM. TYPE:2	Type of alarm for alarm 2	
12 ALM. SRC.:2	Source of value monitored by <b>HIGH, LOW</b> or <b>HIGH/LOW</b> alarm 2	
13 ALARM SP:2	Alarm setpoint for alarm 2 (except for <b>HIGH/LOW</b> )	
14A HIGH SP:2	High alarm setpoint for <b>HIGH/LOW</b> alarm 2	
14B LOW SP:2	Low alarm setpoint for <b>HIGH/LOW</b> alarm 2	
15 DEADBAND :2	Deadband for alarm 2	
16 ALM.:2 OUT.	Output number for alarm 2	
17 LATCHING :2	Latching sequence for alarm 2	
18 ACK.:2	Whether alarm 2 may be acknowledged	
19 POWER UP:2	How alarm 2 will be treated upon power up	
20 MESSAGE:2	Nine character message associated with alarm 2	
21 FAULT	Alarm relay status if fault condition is detected	
22 OUTPUT	Output if the rate-of-change alarm is tripped	
23 RATE TIME	Time period over which a rate-of-change alarm is determined	

**CUST. LINR.**

Parameter	Description	Value
1 1st INPUT	Input signal for the 1st point (of the 15 point curve)	
2 1st PV	Engineering unit value for the 1st point	
3 Xth INPUT	Input signal for the Xth Point (of the 15 point curve)	
4 Xth PV	Engineering unit value for the Xth point	
5 2nd INPUT	Input signal for the 2nd point (of the 15 point curve)	
6 2nd PV	Engineering unit value for the 2nd point	
7 3rd INPUT	Input signal for the 3rd point (of the 15 point curve)	
8 3rd PV	Engineering unit value for the 3rd point	
9 4th INPUT	Input signal for the 4th point (of the 15 point curve)	
10 4th PV	Engineering unit value for the 4th point	
11 5th INPUT	Input signal for the 5th point (of the 15 point curve)	
12 5th PV	Engineering unit value for the 5th point	
13 6th INPUT	Input signal for the 6th point (of the 15 point curve)	
14 6th PV	Engineering unit value for the 6th point	
15 7th INPUT	Input signal for the 7th point (of the 15 point curve)	
16 7th PV	Engineering unit value for the 7th point	
17 8th INPUT	Input signal for the 8th point (of the 15 point curve)	
18 8th PV	Engineering unit value for the 8th point	
19 9th INPUT	Input signal for the 9th point (of the 15 point curve)	
20 9th PV	Engineering unit value for the 9th point	
21 10th INPUT	Input signal for the 10th point (of the 15 point curve)	
22 10th PV	Engineering unit value for the 10th point	
23 11th INPUT	Input signal for the 11th point (of the 15 point curve)	
24 11th PV	Engineering unit value for the 11th point	
25 12th INPUT	Input signal for the 12th point (of the 15 point curve)	
26 12th PV	Engineering unit value for the 12th point	
27 13th INPUT	Input signal for the 13th point (of the 15 point curve)	
28 13th PV	Engineering unit value for the 13th point	
29 14th INPUT	Input signal for the 14th point (of the 15 point curve)	
30 14th PV	Engineering unit value for the 14th point	
31 15th INPUT	Input signal for the 15th point (of the 15 point curve)	
32 15th PV	Engineering unit value for the 15th point	

## CONTROL

Parameter	Description	Value
1 ALGORITHM	Control algorithm used	
2 D. SOURCE	Variable used to determine the derivative value	
3 ACTION:1	Action of the first control output	
4 PV BREAK	Output level if the process variable input is lost	
5 LOW OUT.	Lowest output value that can be achieved in automatic control	
6 HIGH OUT.	Highest output value that can be achieved in automatic control	
7 ACTION:2	Action of the second control output	

**ALARMS**

Parameter	Description	Value
1 ALM. TYPE:1	Type of alarm for alarm 1	
2 ALM. SRC.:1	Source of value being monitored by HIGH or LOW alarm 1	
3 ALARM SP:1	Alarm setpoint alarm 1	
4 DEADBAND:1	Dead band for alarm 1	
5 ALM.:1 OUT.	Output number for alarm 1	
6 LATCHING:1	Latching sequence for alarm 1	
7 ACK.:1	Whether alarm 1 may be acknowledged	
8 POWER UP:1	How alarm 1 will be treated upon power up	
9 MESSAGE:1	Nine character message associated with alarm 1	
10 ALM. TYPE:2	Type of alarm for alarm 2	
11 ALM. SRC.:2	Source of value being monitored by HIGH or LOW alarm 2	
12 ALARM SP:2	Alarm setpoint for alarm 2	
13 DEADBAND :2	Dead band for alarm 2	
14 ALM.:2 OUT.	Output number for alarm 2	
15 LATCHING :2	Latching sequence for alarm 2	
16 ACK.:2	Whether alarm 2 may be acknowledged	
17 POWER UP:2	How alarm 2 will be treated upon power up	
18 MESSAGE:2	Nine character message associated with alarm 2	
19 FAULT	Alarm status if a fault condition is detected	
20 OUTPUT	Output if the rate-of-change alarm is tripped	
21 RATE TIME	Time period over which a rate-of-change will be determined	

**RETRANS.**

Parameter	Description	Values
1 TYPE:2	What is to be retransmitted for retransmission output 2	
2 LOW RANGE:2	Low end of range in eng. units for retransmission output 2	
3 HI RANGE:2	High end of range in eng. units for retransmission output 2	
4 TYPE:3	What is to be retransmitted for retransmission output 3	
5 LOW RANGE:3	Low end of range in eng. units for retransmission output 3	
6 HI RANGE:3	High end of range in engl units for retransmission output 3	
7 TYPE:4	What is to be retransmitted for retransmission output 4	
8 LOW RANGE:4	Low end of range in eng. units for retransmission output 4	
9 HI RANGE:4	High end of range in eng. units for retransmission output 4	



**SELF TUNE**

Parameter	Description	Value
1 TYPE	Type of self tuning algorithm that is available	
2 PRETUNE	Output step size in absolute percent	
3 TUNE PT.	TYPE 1: Defines the PV value at which the output switches off	
4 OUT. STEP	TYPE 2 & 3: Defines output step size in absolute percent	
5 LOW LIMIT	Lower limit PV can reach during Pretune before aborting	
6 HI LIMIT	Upper limit PV can reach during Pretune before aborting	
7 TIMEOUT	Execution time limit for Pretune before aborting	
8 MODE	Control mode after Pretune is completed or aborted	
9 NOISE BND.	Noise band to be used by adaptive tuning algorithm	
10 RESP. TIME	Response time to be used by adaptive tune	
11 DEAD TIME	Time required to wait before responding to output change	

**SPECIAL**

Parameter	Description	Value
1 AUTO. TRIP	How controller automatically trips to auto control form manual	
2 TRIP DEV.	Deviation from setpoint at which controller will trip to auto	
3 DES. OUTPT.	Output value on a trip to manual	
4 POWER UP	Control mode upon power up	
5 PWR. UP:OUT.	Output of the controller is powering up in manual control	
6 PWR. UP: SP	Setpoint upon power up	
7 NO. OF SP	#of setpoints stored for selection by digital input or SET PT key	

## SECURITY

Parameter	Description	Values
1 SEC. CODE	Security code for temporarily unlocking the instrument	
2 SP ADJUST	Lockout status for setpoint changes	
3 AUTO./MAN.	Lockout status of the MANUAL key	
4 SP SELECT	Lockout status of the SET PT key	
5 ALARM ACK.	Lockout status of the ACK key	
6 TUNING	Lockout status for adjustment of tuning parameters	
7 CONFIGURE	Lockout status for Set Up parameters	

## SER COMM.

Parameter	Description	Values
1 STATION	The unit's station address	
2 BAUD RATE	Baud rate	
3 CRC	Whether CRC is being calculated	
4 SHED TIME	Time between communications before controller sheds	
5 SHED MODE	State of the controller if communications is lost (sheds)	
6 SHED OUT.	Output if the unit sheds	
7 SHED SP	Setpoint status if communications is lost	
8 DESIG. SP	Value of the setpoint if controller sheds	

## 6. TUNING

### OVERVIEW

The self tune function of the DPC 535 consists of two distinct components – Pretune and Adaptive Tune. In addition, you may choose from three type of Pretune:

**TYPE 1** - for slow thermal processes.

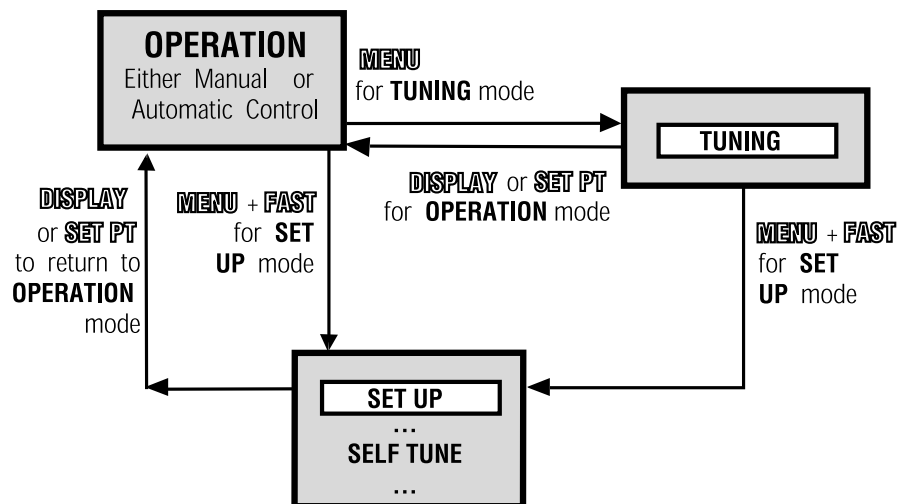
**TYPE 2** - for fast fluid or pressure processes.

**TYPE 3** - for level control applications.

You choose the type of Pretune in the **SELF TUNE** menu.

The Pretune and Adaptive Tune components may be used separately or together.

On the following pages is the step by step guide to the **TUNING** menu parameters.



**Fig. 6.1** Access the Tuning Menu Block

**NOTE:**

For more information about Pretune and Adaptive Tune, refer to section on Tuning applications in Chapter 7.

## TUNING

### 1. ADAPTIVE

Activates the self tune algorithm (upon transfer to automatic control).

- D** **DISABLED**
- **ENABLED**

### 2. PRETUNE

Activates the pretune algorithm (if unit is under manual control).

To initiate the Pretune cycle, press the ▲ or ▼ . Confirm by pressing **ACK** within two seconds.

- D** **NO**

### 3. POWR. BACK

Reduces setpoint overshoot at power up or after setpoint changes.

- D** **DISABLED**
- **ENABLED**

### 4. PROP. BND.:I

Defines the proportional band for PID set 1.

- R** **0.1 to 999.0%**
- D** **50.0%**

### 5. RESET:I

Defines the integral time for PID set 1.

- R** **1 to 9999 seconds**
- D** **20 seconds**

### 6. RATE:I

Defines the derivative time for PID set 1.

- R** **0 to 600 seconds**
- D** **1 second**

TUNING

ADAPTIVE

DISABLED

PRETUNE

NO

POWR. BACK

DISABLED

PROP. BND.:I

50.0

RESET:I

20

RATE:I

1

**MAN. RST.:1****0****CYCLE TM.:1****15.0****DEADBAND:1****2****P.PROP.D.B.****2.0****PID OFST.:1****0****ON/OFST.:1****0****7. MAN. RST.:1 (or LOADLINE:1)**

Defines the manual reset for PID set 1. If using automatic reset, then this specifies the load line out value.

**R 0 to 100%****D 0%****8. CYCLE TM.:1**

Defines the cycle time for control output 1 when using a time proportioning output.

**R 0.3 to 120.0 seconds****D 15.0 seconds****9. DEADBAND:1**

Defines the dead band for control output 1 when using on/off control.

**R 1 to 99999 in engineering units****D 2****10. P. PROP. D.B.**

Defines the dead band setting for a slidewire position proportioning output.

**R 0.5 to 10.0%****D 2.0%****11A. PID OFST.:1**

For duplex applications, defines the offset for the first output.

**R -50.0% to 50.0%****D 0.0%****11B. ON OFST.:1**

For On/Off applications, defines the offset for the first output.

**R -9999 to 99999 in engineering units****D 0**

### 12A. PID OFST.:2

For duplex applications, defines the offset for the second output.

**R** -50.0% to 50.0%

**D** 0.0%

**PID OFST.:2**

0

### 12B. ON OFST.:2

For On/Off applications, defines the offset for the second output.

**R** -9999 to 99999 in engineering units

**D** 0

**ON/OFST.:2**

0

### 13. REL. GAIN:2

Defines the adjustment factor for the second output's proportional band. It is multiplied by the effective gain of output 1 to obtain the second output's proportional band.

**R** 0.1 to 10.0

**D** 1.0

**REL. GAIN:2**

1.0

### 14. CYCLE TM.:2

Defines the cycle time for control output 2 when using a time proportioning output.

**R** 0.3 to 120.0 seconds.

**D** 15.0 seconds

**CYCLE TM.:2**

15.0

### 15. DEADBAND:2

Defines the dead band for control output 2 when using on/off control.

**R** 1 to 99999 in engineering units

**D** 2

**DEADBAND:2**

2

### 16. NO. OF PID

Defines the number of PID sets that will be stored and available for use.

**R** 1 to 8 For numbers > 1, PID TRIP defines tripping between the PID sets

- **SP NUMBER** Number of PID sets = number of local setpoints (specified in NO. OF SP). Each PID set has a respective SP NUMBER.

**NO. OF PID**

1

**PID TRIP**  
**SP VALUE**

**TRIP:1**  
**(D)**

**PROP.BND.:X**  
**(D)**

**RESET:X**  
**(D)**

**RATE:X**  
**1**

- **PV NUMBER** PID Set = the process variable (PVI or PV2) used when PV SOURCE = 1/2: SWITCH or PV SOURCE = 1/2:BACKUP

**D I**

**17. PID TRIP**

For NO. OF PID > 1, defines the variable used to select the various PID sets.

- **PV VALUE** PID set selection based on process variable
- D SP VALUE** PID set selection based on setpoint
- **DEV. VALUE** PID set selection based on deviation from setpoint

**18. TRIP:1**

Defines the value that triggers a change to the primary set (#1) of PID values.

- R** The process variable range
- D** Dependent on the process variable range

**FOR EACH SET OF PID 2 THROUGH 8**, you need to set up the following group of parameters (X represents the PID set number). Set up the parameters as they appear for each set of PID. **The controller designates the values for the active PID parameter in the third display with an “\*” on either side.**

**19. PROP. BND.:X**

Defines the proportional band for PID set X.

- R** 0.1 to 999.0%
- D** 50.0%

**20. RESET:X**

Defines the integral time for PID set X.

- R** 1 to 9999 seconds (increments of 1)
- D** 20 seconds

**21. RATE:X**

Defines the derivative time for PID set X.

- R** 0 to 600 seconds
- D** 1 seconds

**22. MAN. RST.:X (or LOADLINE:X)**

Defines the manual reset (or load line) for PID set X.

**R** 0 to 100%

**D** 0%

<b>MAN.RST.:X</b>
<b>0</b>

**23. TRIP:X**

This defines the value that triggers a change to the Xth set of PID values.

**R** The process variable range

**D** Dependent on the process variable range

<b>TRIP:X</b>
<b>(D)</b>



## TUNING

Parameter	Definition	Values
1. ADAPTIVE	Activates the self tune algorithm	
2. PRETUNE	Activates the pretune algorithm	
3. POWR. BACK	Reduces setpoint overshoot	
4. PROP. BND.:1	Defines the proportional band for PID set 1.	
5. RESET:1	Defines the integral time for PID set 1.	
6. RATE:1	Defines the derivative time for PID set 1.	
7. MAN. RST.:1	Defines the manual reset for PID set 1.	
8. CYCLE TM.:1	Defines the cycle time for control output 1	
9. DEADBAND:1	Defines the dead band for control output 1	
10. P. PROP. D.B.	Defines the dead band setting for a slidewire output.	
11A. PID OFST.:1	For duplex applications, defines the offset for the first output.	
11B. ON OFST.:1	For On/Off applications, defines the offset for the first output.	
12A. PID OFST.:2	For duplex applications, defines the offset for the 2nd output.	
12B. ON OFST.:2	For On/Off applications, defines the offset for the 2nd output.	
13. REL. GAIN:2	Defines the adjustment factor for the output 2 prop. band.	
14. CYCLE TM.:2	Defines the cycle time for control output 2.	
15. DEADBAND:2	Defines the dead band for control output 2.	
16. NO. OF PID	Defines the number of stored and available PID sets.	
17. PID TRIP	Defines the variable used to select the various PID sets.	
18. TRIP:1	Defines the value that triggers a change to primary PID set.	
19. PROP. BND.:2	Defines the proportional band for PID set 2.	
20. RESET:2	Defines the integral time for PID set 2.	
21. RATE:2	Defines the derivative time for PID set 2.	
22. MAN. RST.:2	Defines the manual reset (or load line) for PID set 2.	
23. TRIP:2	Defines the value that triggers a change to the 2nd PID set.	
24. PROP. BND.:3	Defines the proportional band for PID set 3.	
25. RESET:3	Defines the integral time for PID set 3.	
26. RATE:3	Defines the derivative time for PID set 3.	
27. MAN. RST.:3	Defines the manual reset (or load line) for PID set 3.	

30. TRIP:3	Defines the value that triggers a change to the 3rd PID set.	
31. PROP. BND.:4	Defines the proportional band for PID set 4.	
32. RESET:4	Defines the integral time for PID set 4.	
33. RATE:4	Defines the derivative time for PID set 4.	
34. MAN. RST.:4	Defines the manual reset (or load line) for PID set 4.	
35. TRIP:4	This defines the value that triggers a change to the 4th PID set.	
36. PROP. BND.:5	Defines the proportional band for PID set 5.	
37. RESET:5	Defines the integral time for PID set 5.	
38. RATE:5	Defines the derivative time for PID set 5.	
39. MAN. RST.:5	Defines the manual reset (or load line) for PID set 5.	
40. TRIP:5	This defines the value that triggers a change to the 5th PID set.	
41. PROP. BND.:6	Defines the proportional band for PID set 6.	
42. RESET:6	Defines the integral time for PID set 6.	
43. RATE:6	Defines the derivative time for PID set 6.	
44. MAN. RST.:6	Defines the manual reset (or load line) for PID set 6.	
45. TRIP:6	This defines the value that triggers a change to the 6th PID set.	
46. PROP. BND.:7	Defines the proportional band for PID set 7.	
47. RESET:7	Defines the integral time for PID set 7.	
48. RATE:7	Defines the derivative time for PID set 7.	
49. MAN. RST.:7	Defines the manual reset (or load line) for PID set 7.	
50. TRIP:7	This defines the value that triggers a change to the 7th PID set.	
51. PROP. BND.:8	Defines the proportional band for PID set 8.	
52. RESET:8	Defines the integral time for PID set 8.	
53. RATE:8	Defines the derivative time for PID set 8.	
54. MAN. RST.:8	Defines the manual reset (or load line) for PID set 8.	
55. TRIP:8	This defines the value that triggers a change to the 8th PID set.	

## SELF TUNE MESSAGES AND TROUBLESHOOTING

Refer to Chapter 7 for more information on the Self Tune function of the DPC 535 controller.

When the Pretune function terminates, one of the following messages will appear:

Message	Pretune Type	Conclusion/Problem	Corrective Action
<b>COMPLETED</b>	1	PRETUNE has generated initial PID and the Dead Time values	
	2,3	PRETUNE had generated initial PID , Response Time, Noise Band and the Dead Time values	
<b>ABORTED</b>	1,2,3	User has aborted PRETUNE before completion	
<b>LIMIT ERR.</b>	1	The Process variable went beyond the HI LIMIT or LOW LIMIT	Change the HI LIMIT and LOW LIMIT, or the HIGH OUT and LOW OUT, and run Pretune again.
	2,3	The Process variable went beyond the HI LIMIT or LOW LIMIT	Change the HI LIMIT and LOW LIMIT, or the OUT.STEP size and run Pretune again.
	1,2,3	The initial process variable was near or beyond the HI LIMIT or LOW LIMIT	Change the manual output percentage, or the HI LIMIT and LOW LIMIT, and run Pretune again.
<b>TIMEOUT</b>	1,2,3	TIMEOUT limit was reached before Pretune completed.	Set a longer TIMEOUT period and/or increase the OUT.STEP size, and run Pretune again.
<b>NOISE ERR.</b>	1,2,3	Too much PV noise was detected	Eliminate the noise source (if possible) or increase the OUT.STEP and run Pretune again.
<b>INPUT ERR.</b>	1,2,3	PV or Cold Junction break detected during Pretune	Check the described conditions and make correction or repairs.
	1,2,3	PV HIGH or PV LOW detected during Pretune	
	1,2,3	SLIDEWIRE break detected during Pretune	
	1,2,3	Remote SP Break detected during Pretune.	
<b>OUT. ERROR</b>	1,2,3	The initial control output is outside the high and low limits defined in the Control menu	Change the manual output percent and run Pretune again.
<b>DATA ERR.</b>	2,3	The PV moved too quickly to be analyzed	Decrease the OUT.STEP size and run Pretune again.
<b>ZERO ERR.</b>	2,3	One or more model parameters are calculated to be zero	Increase the OUT.STEP size and run Pretune again.
<b>DEV. ERROR</b>	1	The initial PV is too close to the TUNE PT.	Move TUNE PT. (or the Setpoint if TUNE PT. is Automatic) farther from the process variable and run Pretune again.
<b>RETRY</b>	1,2,3	The Process variable went beyond the HI LIMIT or LOW LIMIT	Check if any PID values were generated and if they are acceptable. If not, eliminate noise sources (if possible) and run Pretune again.

If Pretune and Adaptive Tune do not generate optimal PID values for control, check the following menu entries:

Message	Potential Problem	Corrective Action
<b>RESPONSE TIME</b>	Adaptive Tune cannot run if RESPONSE TIME is inaccurate	Run TYPE 2 or TYPE 3 Pretune to obtain the correct value, or enter it manually.
<b>NOISE BAND</b>	Adaptive Tune cannot compensate for PV oscillation due to hysteresis of output device (e.g., a sticky valve).	Set NOISE BAND large enough to prevent Adaptive Tune from acting on the oscillation. If oscillation is not acceptable, consider replacing valve.
<b>PRETUNE</b>	Pretune does not develop optimum PID parameters.	Wrong pretune TYPE selected. Refer to Chapter 7, the section on Self Tune.

## 7. APPLICATIONS

The DPC 535 controller provides a variety of user-programmable control features and capabilities. The following topics are included in this chapter:

A. Control Type .....	71	L. Load Line .....	97
B. Alarms .....	72	M. Security .....	97
C. Duplex Control .....	76	N. Reset Inhibition .....	98
D. Staged Outputs .....	83	O. Process Variable Reading Correction .....	98
E. Retransmission .....	83	P. Serial Communications .....	99
F. Multiple Setpoints .....	87	Q. Cascade Control .....	100
G. Multiple Sets of PID Values .....	87	R. Ratio Control .....	103
H. Powerback .....	88		
I. Self Tune—POWERTUNE® .....	89		
J. Ramp-to-Setpoint .....	94		
K. Input Linearization .....	95		

### A. CONTROL TYPE

#### Software Configuration

- Go to the **CONTROL** menu.
- For the parameter **ALGORITHM**, select the type of DPC 535 control:
  - ON-OFF**

“Crude” control similar to a household thermostat. Used primarily on slow, stable processes where moderate deviation (cycling) around setpoint is tolerable. Only available with SSR, SSR Drive, and relay outputs.
  - P**

Proportional only control. Provides much better control than on/off. Used on processes that are less stable or require tighter control, but have few load variations and do not require a wide range of setpoints.
  - PI**

Proportional plus integral control. In addition to proportional control, it compensates for control errors due to wide range of setpoints or load requirements. The integral term works to eliminate offsets.
  - PD**

Proportional plus derivative control. In addition to proportional control, it compensates for control errors due to fast load variations.

**NOTE:**

Controller capabilities depend upon the specified hardware option.

**NOTE:**

Specifying a variable other than the setpoint (SP) to **HIGH ALARM** and **LOW ALARM** allows for greater flexibility in creating alarm and control strategies.

- **PID**

Proportional plus integral plus derivative control. In addition to proportional control, it compensates for changes in setpoint, load requirements and process variations.

- **PID/ON-OFF**

Only available with Duplex control. First output uses the PID algorithm, while second output uses on/off control.

3. For algorithms using the derivative function (D), choose the conditions for the derivative term:

Scroll to parameter D. SOURCE

- For derivative action based on error, or deviation from setpoint, choose DEVIATION
- For derivative action based on process variable changes, choose PV.

## B. ALARMS

The DPC 535 controller has two extremely flexible and powerful software alarms. The number of available outputs limits how alarms are linked to relays. A Global Alarm feature allows all alarms to be assigned to the same relay.

The DPC 535 indicates an alarm condition by:

- Lighting up the alarm icon(s)
- Displaying a custom message in the 3rd display
- Illuminating the **ACK** key (if the alarm is acknowledgeable)

### Software Configuration

1. Access the ALARM menu.
2. Set values for the following parameters. All possible values are shown.

#### **ALM.TYPE:1** and **ALM. TYPE:2**

Specifies the type of alarm to implement. Selection includes:

- **HIGH ALARM**

High process variable alarm. Occurs when the process variable exceeds the alarm setpoint.

- **LOW ALARM**

Low process variable alarm. Occurs when the process variable goes below the alarm setpoint.

- **HIGH/LOW**

Combination of high and low alarms. Occurs when the PV exceeds the individually set high or low setpoint.

- **BAND**

Creates a band centered around the control setpoint, that is twice the alarm setpoint. Alarm occurs when the process variable travels outside of this band. The alarm is dependent on the control setpoint. As the control setpoint changes, the band adjusts accordingly.

For example, if the control setpoint is 500 and the alarm setpoint is 25, then the band extends from 475 to 525.

- **DEVIATION**

Similar to the band alarm but creates a band only on one side of the control setpoint. Alarm occurs when the process variable deviates from the control setpoint by an amount greater than the alarm setpoint. This alarm is dependent on the control setpoint; as the control setpoint changes, the alarm point changes.

For example, if the control setpoint is 500 and the alarm setpoint is +50, then an alarm occurs when the process variable exceeds 550. In order for an alarm to occur when the process variable drops below 450, select an alarm setpoint of -50.

- **MANUAL**

Alarm occurs when the controller is put into manual mode of operation. This may be useful for security purposes or to alert the operator that DPC 535 is no longer under automatic control.

- **RATE**

Alarm occurs when the process variable changes at a rate greater than what is specified by the alarm setpoint and time base. This alarm helps to anticipate problems before the process variable can reach an undesirable level.

For example, if the alarm setpoint is 10 with a time base of 5 seconds, an alarm occurs whenever a change in process variable greater than 10 occurs in 5 seconds.

For HIGH , LOW or HIGH/LOW alarms, specifies the variable (source) upon which a selected alarm is based. Selection includes:

- **PV**
- **PV2**
- **SP**
- **RAMP SP**
- **DEVIATION**
- **OUTPUT**

#### **ALARM SP:1 and ALARM SP:2**

Defines the point at which an alarm occurs. For a RATE (rate of change) alarm, it specifies the amount of change (per RATE TIME period) that must occur before the alarm activates. A negative value specifies a negative rate-of-change. Does not apply to HIGH/LOW alarms.

#### **HIGH SP:1 and HIGH SP:2**

For a HIGH/LOW alarm, defines the high setpoint at which an alarm occurs.

#### **LOW SP:1 and LOW SP:2**

For a HIGH/LOW alarm, defines the low setpoint at which an alarm occurs.

#### **DEADBAND:1 and DEADBAND:2**

Specifies the range through which the process variable must travel before leaving an alarm condition (see alarm examples at the end of this section). Prevents frequent alarm oscillation or “chattering” if the process variable has stabilized around the alarm point.

#### **ALM.1 OUT and ALM.2 OUT**

For any enabled alarm, selects the output number to which the selected alarm will be assigned. It is possible to assign both alarms to the same output relay, thus creating a “global” alarm .

#### **LATCHING:1 and LATCHING:2**

A latching (YES) alarm will remain active after leaving the alarm condition unless it is acknowledged. A non-latching (NO) alarm will return to the non-alarm state when leaving the alarm condition without being acknowledged.

## ACK.:1 and ACK.:2

For any enabled alarm, enables or disables operator use of the **ACK** key to acknowledge an alarm at any time, even if the control process is still in the alarm condition.

A latching alarm can always be acknowledged when it is out of the alarm condition. When either alarm is available to be acknowledged, the **ACK** key will be illuminated. If both alarms are acknowledgeable, pressing **ACK** will first acknowledge alarm #1. Pressing **ACK** a second time will acknowledge alarm #2.

## POWER UP:1 and POWER UP:2

For any enabled alarm, selects the alarm condition upon power up. Choices are:

- **NORMAL**

Controller will power up in alarm only if it is in alarm condition.

- **ALARM:**

Controller always powers up in alarm regardless of system's alarm condition. This is an excellent way to activate an alarm if there has been a power failure.

- **DELAYED**

Controller will never power up in alarm, regardless of system's alarm condition. The system must leave and reenter the alarm condition before the alarm will activate. This is typically used to avoid alarms during start up.

## MESSAGE:1 and MESSAGE:2

Allows user to specify a nine-character message to be displayed when the respective alarm is active. If both alarms are active or any other diagnostic message is present, the messages will alternate.

## FAULT

Activates an alarm if the process variable signal is lost. Assign this function to either Alarm 1 or Alarm 2 (not both). This action is in addition the selected alarm type (additive alarm function).

## OUTPUT

For a RATE alarm, selects the output action. Use to obtain early indication of a possible break in the process variable signal. Select PV BREAK to have rate-of-change alarm take the same action as

### Alarm Parameters Reference

#### For Alarm 1

Parameter	Description
ALM. TYPE:1	Type
ALM. SRC.:1	Source
ALARM SP:1	Setpoint
HIGH SP:1	High setpoint
LOW SP:1	Low setpoint
DEADBAND:1	Deadband
ALM.:1 OUT.	Output number
LATCHING:1	Latching sequence
ACK.:1	Acknowledging
POWER UP:1	Status on power up
MESSAGE:1	Message

#### For Alarm 2

Parameter	Description
ALM. TYPE:2	Type
ALM. SRC.:2	Source
ALARM SP:2	Setpoint
HIGH SP:2	High setpoint
LOW SP:2	Low setpoint
DEADBAND:2	Deadband
ALM.:2 OUT.	Output number
LATCHING:2	Latching sequence
ACK.:2	Acknowledging
POWER UP:2	Status on power up
MESSAGE:2	Message

#### For either alarm

(depending on choices)

Parameter	Description
FAULT	Fault assignment
OUTPUT	Output action for rate
RATE TIME	Time base for rate



a detection of a break in the process variable signal (where it trips to manual control at a predetermined output).

### RATE TIME

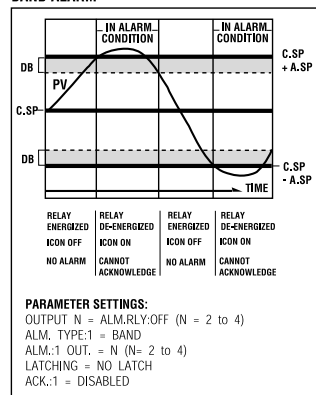
For RATE alarms, defines the time period over which a discrete change in process variable must occur for the rate alarm to be activated. The amount of change is defined by the alarm setpoint. The rate-of-change is defined as the amount of change divided by the time period.

#### Example

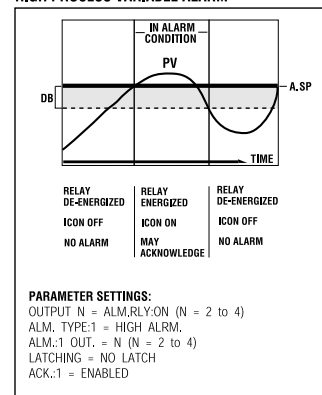
- A. If the alarm setpoint is set to 10 and the time base is set to 1 second, the rate of change is 10 units per second.
- B. If the alarm setpoint is set to 100 and the time base set to 10, the rate of change is also 10 units per second.

In example A, the process variable would only have to experience a ten unit change over a short period of time, while in Example B, it would require a 100 unit change over a ten second period. Example A is much more sensitive than Example B. In general, for a given rate-of-change, the shorter the time period, the more sensitive the rate alarm.

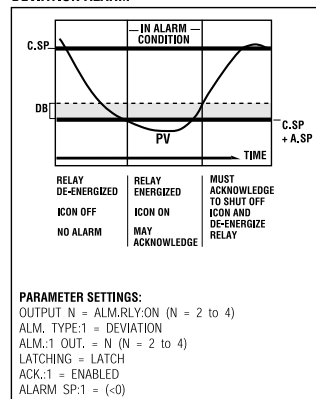
#### BAND ALARM



#### HIGH PROCESS VARIABLE ALARM



#### DEVIATION ALARM



#### POWER UP ALARM

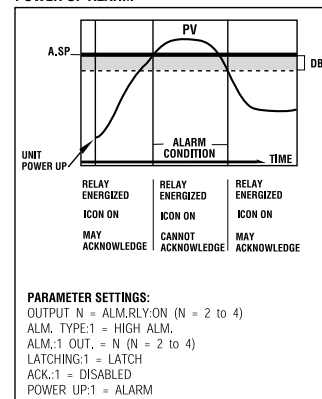


Fig. 7.1 Alarm Samples

## C. DUPLEX CONTROL

The Duplex control algorithm enables two discrete control outputs for the control loop. Duplex control is commonly used for applications that require both heating and cooling or when 2 control elements are needed to achieve the desired result.

### Hardware Configuration

- The controller must have two output modules assigned to the loop (any combination of output modules).

### Software Configuration

1. Go to the **CONFIG.** menu.

Set **CTRL.TYPE** to DUPLEX.

2. To use different algorithms for each output (PID for the first, and On/Off for the second):

Go to the **CONTROL** menu.

Set **ALGORITHM** to PID:ON/OFF.

3. To make the control action for each output independent of the other:

Go to the **CONTROL** menu.

Set **ACTION:1** or **ACTION:2** to either DIRECT or REVERSE action based on the diagrams in the output examples section (Figures 7.2 through 7.8).

4. Go to the **TUNING** menu.

Set values for **PID OFST:1** (or **ON OFST:1**) and **PID OFST:2** (or **ON OFST:2**). These parameters allow the user to independently offset the point at which output 1 and output 2 become active. **PID OFFSET** units are in percent (%) of control output; **ON OFST** is in engineering units. The settings can be used to make sure there is a dead band, i.e., no controller output around setpoint. They can also be used to overlap output 1 and output 2 so that both are “on” in a small band around setpoint.

5. Set **MAN. RESET** (manual reset) term to 50%. This causes the PID output to be 50% when there is zero error. This term is still active as a “load line” setting when using automatic reset (integral), so set it to 50% whether using automatic reset or not.

### NOTE:

The duplex output states vary depending upon:

1. Control Type (PID, On/Off, etc.)
2. Control Action (DA, RA)
3. Output Limits
4. Output Gap or Overlay, and
5. Output 2 Relative Gain and PID% Output.

Please refer to the output state examples in this section to confirm that the configuration is appropriate for the process.

### NOTE:

Set manual reset/load line parameters to 50% when using Duplex control (**MAN. RST.:X** parameter is in the **TUNING** menu.)

6. **REL. GAIN** (relative gain) changes the gain of Output 2 relative to Output 1. Note that the relative gain can limit the maximum output available for Output 2 when using PID control.
7. Go to the **CONTROL** menu.

Set **LOW OUT.** and **HIGH OUT.** to limit the maximum or minimum outputs from Output 1 and Output 2. The actual limitation on the outputs is dependent on the offset settings, the relative gain setting and the control action.

### Duplex Output State Examples

The following Duplex examples represent a variety of ways this function can be set up. PID control examples show the PID output percentage on the horizontal axis, and On/Off control examples show the process variable on the horizontal axis. The vertical axes are the output of each physical output. Most of these examples use the first output as heating and the second output as cooling.

When using PID control, the DPC 535 controller actually displays the PID output.

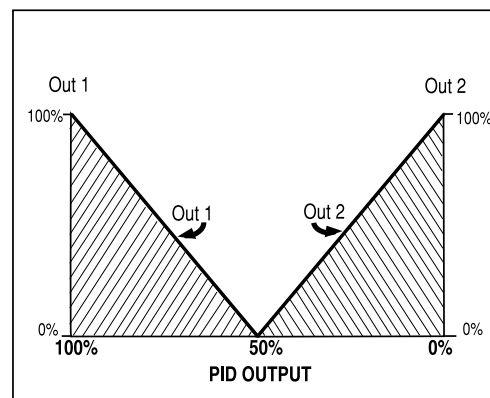
To relate this output to the actual physical output, locate the PID output on the horizontal axis. Draw a vertical line at that point. At the intersection of this vertical line and the respective output line, draw a horizontal line. The physical output is the value where this horizontal line intersects the respective axis.

The illustrations assumes a manual reset/load line term of 50%. Therefore, at zero error (process variable equals setpoint) the PID output is 50%.

### Duplex with reverse and direct acting outputs

A reverse acting output 1 and a direct acting output 2 with: no offset, no restrictive outputs limits, and a neutral relative gain with PID control.

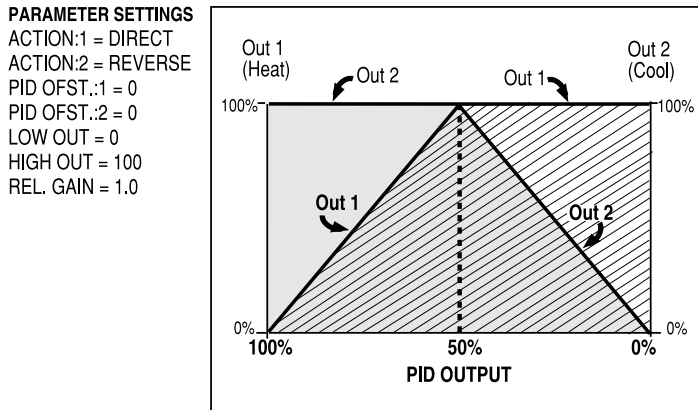
PARAMETER SETTINGS  
 ACTION:1 = REVERSE  
 ACTION:2 = DIRECT  
 PID OFST.:1 = 0  
 PID OFST.:2 = 0  
 LOW OUT = 0  
 HIGH OUT = 100  
 REL. GAIN = 1.0



**Fig. 7.2 Duplex with reverse and direct acting outputs**

### Duplex with direct and reverse acting outputs

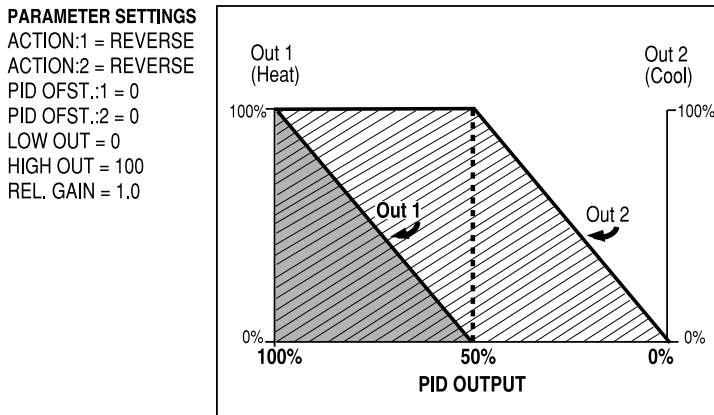
A reverse acting output 1 and a direct acting output 2 with: no offset, no restrictive output limits, and a neutral relative gain with PID control.



**Fig. 7.3 Duplex with direct and reverse acting outputs**

### Duplex with 2 reverse acting outputs

Two reverse acting outputs with: no offset, no restrictive output limits, and a neutral relative gain with PID control.



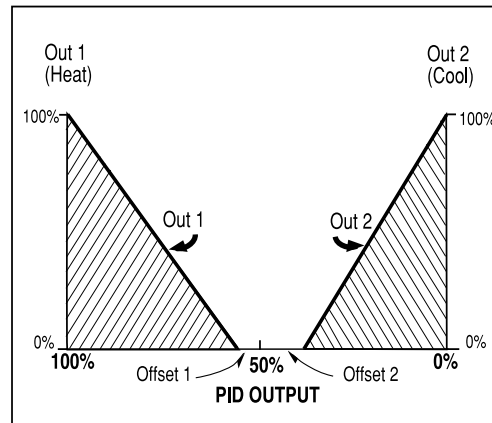
**Fig. 7.4 Duplex with two reverse acting outputs**

### Duplex with a gap between outputs

A reverse acting output 1 and a direct acting output 2 react with: a positive offset for output 1 and a negative offset for output 2 (assume no restrictive output limits and a neutral relative gain with PID control).

On the graph, a positive offset refers to an offset to the left of 50%; a negative offset is to the right of 50%.

**PARAMETER SETTINGS**  
 ACTION:1 = REVERSE  
 ACTION:2 = DIRECT  
 PID OFST.:1 = + VALUE  
 PID OFST.:2 = - VALUE  
 LOW OUT = 0  
 HIGH OUT = 100  
 REL. GAIN = 1.0



**Fig. 7.5 Duplex with a gap between outputs**

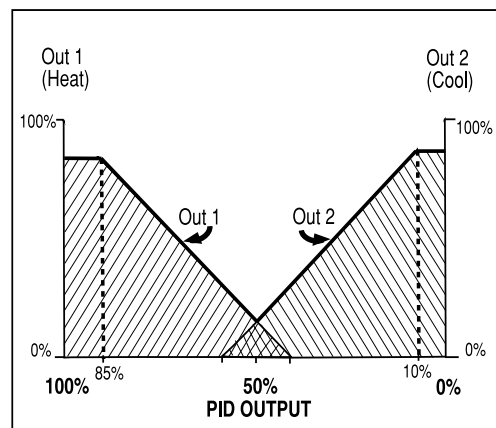
**Duplex with a overlapping outputs and output limits**

A reverse acting output 1 and a direct acting output 2 with: a negative offset for output 1, a positive offset for output 2, and restrictive high and low output limits with PID control.

This combination of offsets results in an overlap where both outputs are active simultaneously when the PID output is around 50%.

The output limits are applied directly to the PID output. This in turn limits the actual output values. In this example, the high output maximum limits the maximum value for output 1, while the low output minimum limits the maximum value for output 2. The value the actual outputs are limited to depends on offset settings, control action and relative gain setting with PID control.

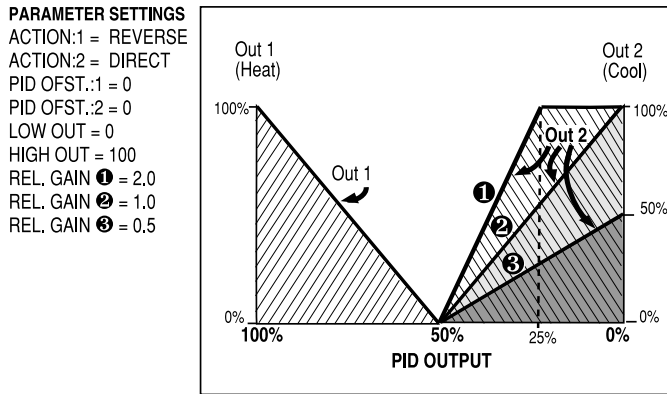
**PARAMETER SETTINGS**  
 ACTION:1 = REVERSE  
 ACTION:2 = DIRECT  
 PID OFST.:1 = - VALUE  
 PID OFST.:2 = + VALUE  
 LOW OUT = 10%  
 HIGH OUT = 85%  
 REL. GAIN = 1.0



**Fig. 7.6 Duplex with overlapping outputs and ouput limits**

### Duplex with various relative gain settings

A reverse acting output 1 and a direct acting output 2 with: various relative gain settings (assume no offset or restrictive outputs) with PID control.



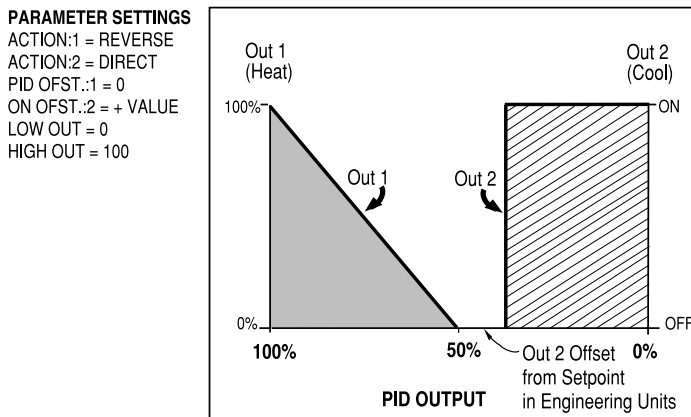
**Fig. 7.7 Duplex with various relative gain settings**

Notice that the relative gain setting does not affect output 1. In this example, a relative gain setting of 2.0 (curve 1) results in output 2 reaching its maximum value at a PID output of 25%. A relative gain setting of 1.0 results in output 2 reaching its maximum value at a PID output of 0%. A relative gain setting of 0.5 results in output 2 reaching a maximum of 50% at a PID output of 0%.

### Duplex with one ON/OFF output

A reverse acting output 1 and a direct acting, on/off output 2 with a positive offset.

Relative gain does not apply when using duplex with an on/off output. The deadband setting for output 2 works the same as the deadband in single on/off control (the deadband effect for output 2 is not illustrated here).



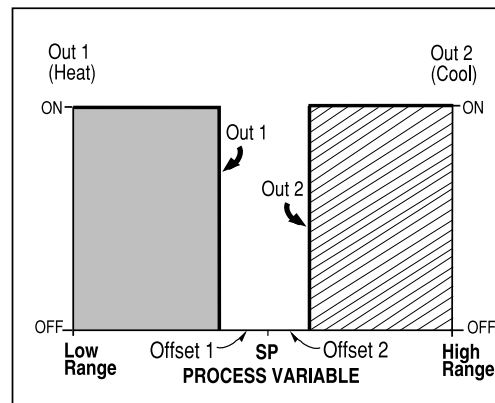
**Fig. 7.8 Duplex with one ON/OFF output**

### Duplex with two ON/OFF outputs

A reverse acting on/off output 1 and a direct acting on/off output 2 with a negative offset for output 1 and a positive offset for output 2.

Note that here the horizontal axis is expressed in terms of process variable rather than PID output.

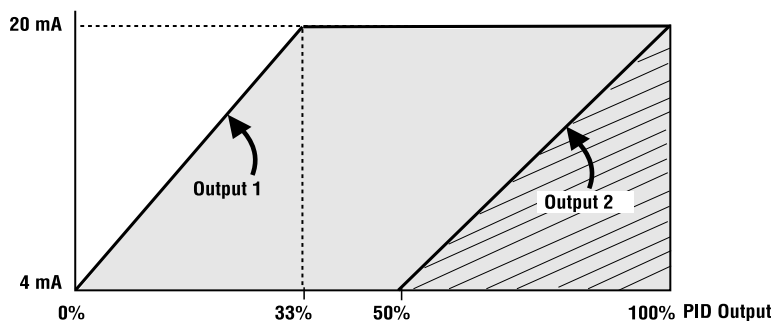
PARAMETER SETTINGS  
 ACTION:1 = REVERSE  
 ACTION:2 = DIRECT  
 ON OFST.:1 = - VALUE  
 ON OFST.:2 = + VALUE



**Fig. 7.8 Duplex with two ON/OFF outputs**

### D. STAGED OUTPUTS

With staged outputs, one analog output can vary its signal (e.g., 4-20 mA) over a portion of the PID output range. The second analog output then varies its signal over another portion of the PID output range. This is an excellent method to stage two control valves or two pumps using standard control signal ranges.



**Fig. 7.10 Staged Outputs Example**  
**OUT1 STOP was set to 33% and OUT2 STRT**  
**was set to 50%.**

### **Hardware Configuration**

- The controller must have analog output modules installed in the first two output sockets.

### **Software Configuration**

1. Go to the **CONFIG.** menu.  
Set **CTRL. TYPE** to STAGED.
2. Go to the **CONTROL** menu.
3. For **OUT1 STOP**, specify where the first output reaches 100%.
4. For **OUT2 START**, specify where the second output begins.

## **E. RETRANSMISSION**

The retransmission feature may be used to transmit a milliamp signal corresponding to the process variable, target setpoint, control output, or actual setpoint to another device. A common application is to use it to record one of these variables with a recorder.

### **Hardware Configuration**

- There must be an analog module installed in output socket 2, 3 or 4.

### **Software Configuration**

Up to two outputs can be configured for retransmission. The menu will scroll through the configuration parameters for specified value "X" (2, 3 or 4).

1. Go to the **CONFIG.** menu.
2. For **OUTPUT:2**, **OUTPUT:3** and **OUTPUT:4** parameters, set one or two of them to RETRANS.
3. Go to the **RETRANS.** menu.
4. Set the corresponding parameter, **TYPE:X**, for the first retransmission output to define what is being transmitted: the process variable, setpoint, ramping setpoint or output.

### **NOTE:**

*For an analog output module for retransmission that was not factory-installed, calibrate the output for maximum accuracy. Refer to Appendix 4 for details on calibration.*



## **F. MULTIPLE SETPOINTS**

The DPC 535 can store up to eight local setpoints and use a remote setpoint. One application of this feature is configuring the controller to restrict operators to discrete setpoint choices. The DPC 535 can also store multiple sets of PID parameters (see next section).

### **Software Configuration**

1. Go to the **SPECIAL** menu.
2. Set **NO. OF SP** to the number of local setpoints desired.
3. Use the **SET PT** key to scroll to each local setpoint and set it to the desired value with the ▲ or ▼ keys.
4. To link the PID sets to the corresponding local setpoint:

Go to the **TUNING** menu.

Set **NO. OF PID** to SP NUMBER.

For details on multiple sets of PID, refer to the next section in this chapter.

### **Basic Operating Procedures**

To select a set point, toggle the **SET PT** key to scroll through the setpoints. The displayed setpoint becomes active after two seconds of key inactivity.

The digital inputs can also be used to select the active setpoints. A single digital input may be used for selecting the second setpoint, SP2. A set of four digital inputs may be used, to select up to 8 setpoints (see the section in this Chapter in Digital Inputs).

The **SET PT** key is lit when a setpoint other than the primary local setpoint is active.

## **G. MULTIPLE SETS OF PID VALUES**

The DPC 535 has the ability to store up to eight sets of PID values. This can be a valuable feature for operating the controller under conditions which require different tuning parameters for optimal control. There are various methods of selecting which set should be active. These methods are explained in this section.

## Software Configuration

1. Go to the **TUNING** menu.
2. **NO.OF PID** is the desired number of PID sets to be stored. SP VALUE automatically sets this value equal to the number of stored local setpoints (each PID set will be active when its respective local setpoint is active).
3. **PID TRIP** determines which variable selects the various PID sets: process variable, setpoint or deviation from setpoint.
4. **TRIP:X** defines the point (in the PV range) at which that set of PID values become active.

## Basic Operating Procedures

A PID set can be selected in one of four ways.

- For **NO. OF PID** = PV NUMBER, the PID set (1 or 2) is selected when PV1 or PV2 is used.
- For **NO. OF PID** = SP NUMBER, the active set of PID values is the same as the active setpoint. For example, if SP3 is active, then PID set #3 will be active.
- When using PID trip values, a PID set becomes active when the variable exceeds its trip point.

For example, if **PID TRIP** = SETPOINT, and **TRIP:2** = 500, the second set of PID values becomes active when the setpoint exceeds 500, and remains active until the setpoint drops below 500 or exceeds the next highest trip point. The PID set with the lowest trip point is also active when the trip variable is less than the trip value. (The user can set the lowest trip point = the low end of the process variable range, but this is not required.)

- A digital input can be set to trip to the second set of PID upon closure, which overrides a selection based on trip points.

## Using with Adaptive and Pretune

The DPC 535 can be programmed to automatically set the PID values using the Pretune and Adaptive Tuning functions. For both functions, the tuned set of PID is that which is active upon initiation of the tuning function.

The controller cannot trip to other PID sets (based on trip point or the digital input contact) until Adaptive Tuning is disabled. However, if the PID set is tied to the corresponding local setpoint, the active PID set values will change with the local setpoint.

Each PID set has 5 parameters that control its function—proportional band, reset, rate, manual reset (or loadline), and trip point. For each set (2 thru 8), these values have to be manually set.

1. Press **MENU** to access the **TUNING** menu.
2. Set values for parameters 1 thru 20 (these include the first PID set)
3. Press **MENU** to access these parameters for each additional PID set (2 through 8): **PROP. BND, RESET, RATE, MAN. RST.** and **TRIP.**

## **H. POWERBACK**

POWERBACK is a proprietary algorithm which, when invoked by the user, reduces or eliminates setpoint overshoot at power up or after setpoint changes. Powerback monitors the process variable to make predictive adjustments to control parameters, which in turn helps to eliminate overshoot of the Setpoint.

### **Software Configuration**

1. Go to the **TUNING** menu.
2. Set **POWR.BACK** parameter to ENABLED.
3. Go to the **SELF TUNE** menu.
4. For **DEAD TIME**, set the value (time) that the controller should wait before invoking an output change. This value is typically the dead time of the process. Or, let Pretune calculate the dead time, then complete just steps 1 and 2 above.

## **I. SELF TUNE**

The Self Tune function of the DPC 535 consists of two distinct components, Pretune and Adaptive Tune. These components may be used independently or in conjunction with one another. For best results, we recommend using them together.

### **Pretune**

This algorithm has three versions. Choose the type that most closely matches the process to optimize the calculation of the PID parameters. The three Pretune types are:

- **TYPE 1**                      **Normally used for slow thermal processes**
- **TYPE 2**                      **Normally used for fast fluid or pressure processes**
- **TYPE 3**                      **Normally used for level control applications**

Pretune is an on-demand function. Upon initiation, there is a five second period during which the controller monitors the activity of the process variable. Then the control output is manipulated and the response of the process variable is monitored. From this information, the initial Proportional Band, Reset and Rate (P, I and D values) and dead time are calculated. When using TYPE 2 or TYPE 3 Pretune, the Noise Band (**NOISE BND.**) and Response Time (**RESP. TIME**) will also be calculated.

In order to run this algorithm, the process must fulfill these requirements:

- The process must be stable with the output in the manual mode;
- For tuning a non-integrating process, the process must be able to reach a stabilization point after a manual step change; and
- The process should not be subject to load changes while Pretune operates.

If these conditions are not fulfilled, set the Adaptive Tune to run by itself.

### Adaptive Tune

Adaptive Tune continuously monitors the process and natural disturbances and makes adjustments in the tuning parameters to compensate for these changes. In order to make accurate calculations, Adaptive Tune needs noise band and response time values. Pretune TYPE 2 and TYPE 3 automatically calculate these values. These values may also be entered or changed manually in the **SELF TUNE** menu. For Pretune TYPE 1, Noise Band and Response Time parameters must be entered manually.

Figure 7.12 illustrates the relationship between Pretune and Adaptive Tune

## Software Configurations

### Pretune by Itself

1. Go to the **SELF TUNE** menu (press **MENU+FAST**)
2. Set the **TYPE** parameter to PRETUNE.
3. Set the **PRETUNE** type to the one that best matches the process (see above section).
4. The next parameter, **TUNE PT.**, appears only for TYPE 1 pretune. This parameter sets the PV point at which the output will switch off. In thermal processes, this will help prevent overshoot. The default is AUTOMATIC.

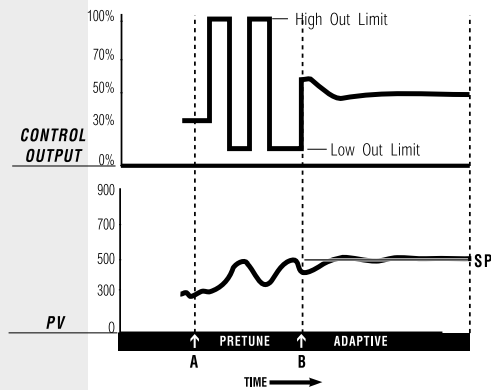
### CAUTION!

Disable Adaptive Tune before altering process conditions (e.g., for shutdown, tank draining, etc.). Otherwise, the DPC 535 will attempt to adapt the Tuning parameters to the temporary process conditions.

Adaptive Tune can be disabled via digital input (if applicable see Digital Inputs in this chapter), or via menus:

1. Go to the **TUNING** menu.
2. Go to parameter **ADAPTIVE**. Change the value to **DISABLED**.

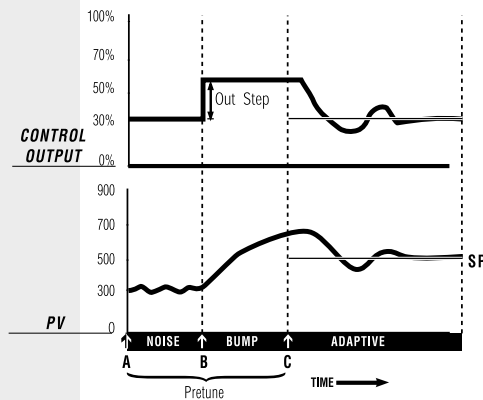
5. Set the value for **OUT STEP**. This parameter defines the size of bump to be used. The resulting disturbance must change the process variable by an amount that significantly exceeds the peak-to-peak process noise, but does not travel beyond the “normal” process variable range.
6. The next two parameters, **LOW LIMIT** and **HI LIMIT**, set the process variable boundaries. If these boundaries are exceeded during the Pretune, the pretune cycle will abort and return to manual control at the output level prior to the initiation of pretune.



**TYPE 1 Pretune/Adaptive Control**

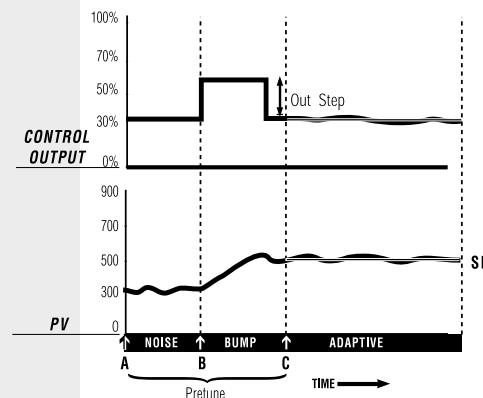
- A to B is ON/OFF control to determine initial PID values.
- B is Pretune completed, so Adaptive PID control begins if ENABLED.

**Note:** Noise Band and Resp. Time must be entered before enabling Adaptive TUne)



**TYPE 2 Pretune/Adaptive Control**

- A to B is a 5 second noise band measurement.
- B to C is an open loop bump test to determine initial PID values and response time.
- C is Pretune completed, so Adaptive PID control begins if ENABLED.



**TYPE 3 Pretune/Adaptive Control**

- A to B is a 5 second noise band measurement.
- B to C is an impulse to determine initial PID values and response time.
- C is Pretune completed, so Adaptive PID control begins if ENABLED.

**Fig. 7.12 Pretune TYPE 1, 2 and 3 with Adaptive Tune**

7. The next parameter, **TIMEOUT**, defines the maximum time in minutes within which pretune must complete its calculations before it is aborted.

The first time a pretune is performed, set **TIMEOUT** to its maximum value. Make note of the length of the pretune cycle. Then, adjust **TIMEOUT** to a value about twice the pretune time.

The purpose of this parameter is to prevent a Pretune cycle from continuing for an excessive time if a problem develops. The value has no impact on the PID values being calculated.

8. Next is **MODE**. This defines what mode the controller will enter when pretune is completed. Select **MANUAL** if there will be a need to review PID parameters before attempting to control with them; the default **AUTOMATIC**.
9. **RESP. TIME** defines the amount of damping for the process. The choices include **FAST** (results in approximately 20% overshoot), **MEDIUM** (results in approximately 10% overshoot), and **SLOW** (<<1%).
10. Place the controller under manual control.
11. Access the **TUNING** menu (press **MENU**).  
Set the first parameter, **ADAPTIVE**, to **DISABLED**.
12. Activate the next parameter, **PRETUNE**.
13. Press **ACK** to begin Pretuning.  
The 3rd display will show the message **EXECUTING**.
14. When Pretune is complete, the 3rd display will show **COMPLETED** for two seconds and then return to the current menu display.

### **Pretune TYPE I & Adaptive Tune**

1. Go to the **SELF TUNE** menu.
2. Set **TYPE** to **BOTH**.
3. Set **PRETUNE** to **TYPE 1**.
4. Set a value for **OUTSTEP**.
5. Set **NOISE BND** parameter.
6. Set the **RESP. TIME** parameter.

7. Make sure that the process is reasonably stable and place the controller under manual control.

8. Press **MENU** to access the **TUNING** menu.

Set **ADAPTIVE** to ENABLED. The Adaptive Tuning cycle does not begin the controller is under automatic control.

9. Activate the next parameter, **PRETUNE**.

10. Press **ACK** to begin Pretuning.

The 3rd display will show the message EXECUTING.

11. When Pretune is complete, the 3rd display will show COMPLETED for two seconds and then return to the current menu display.

The controller will automatically transfer to automatic control upon completion of Pretune if set to do so, or upon manual transfer.

*Figure 7.12 illustrates the operation of Pretune TYPE 1 with Adaptive Tune.*

#### **Pretune TYPE 2 or 3 & Adaptive Tune**

1. Go to the **SELF TUNE** menu.

2. Set the **TYPE** parameter to BOTH.

3. Set the **PRETUNE** parameter to TYPE 2 or TYPE 3.

4. DO NOT Enter values for **NOISE BND** and **RESP TIME**. The Pretune algorithm will calculate these values.

2. Make sure that the process is reasonably stable and place the controller under manual control.

3. Press **MENU** to access the **TUNING** menu.

4. Set parameter **ADAPTIVE** to ENABLED. The Adaptive Tuning cycle does not begin the controller is under automatic control.

4. Activate the next parameter, **PRETUNE**.

5. Press **ACK** to begin Pretuning.

The 3rd display will show the message EXECUTING.

6. When Pretune is complete, the 3rd display will show COMPLETED for two seconds and then return to the current menu display.

The controller will automatically transfer to automatic control upon completion of Pretune if set to do so, or upon manual transfer.

Figure 7.12 illustrates the operation of Pretunes TYPE 2 and TYPE 3 with Adaptive Tune.

### Adaptive Tune by Itself

1. Go to the **SELF TUNE** menu.
2. Set the **TYPE** parameter to ADAPTIVE.
3. Press **MENU** to access the TUNING menu.
4. Set the **ADAPTIVE** parameter to ENABLED. The Adaptive Tuning cycle does not begin the controller is under automatic control.

If Pretune results are poor or process conditions do not allow Pretune to run, the Adaptive Tune parameters can be manually configured. Proper setting of the noise band and response time parameters will yield excellent adaptive control without running the Pretune function.

1. Go to the **SELF TUNE** menu.
2. Set **NOISE BND**.

The noise band is chosen to distinguish between disturbances which affect the process and process variable “noise.” The controller functions to compensate for disturbances (i.e., load changes), but it cannot compensate for process noise. Attempting to do this will result in degraded controller performance. The Noise Band is the distance

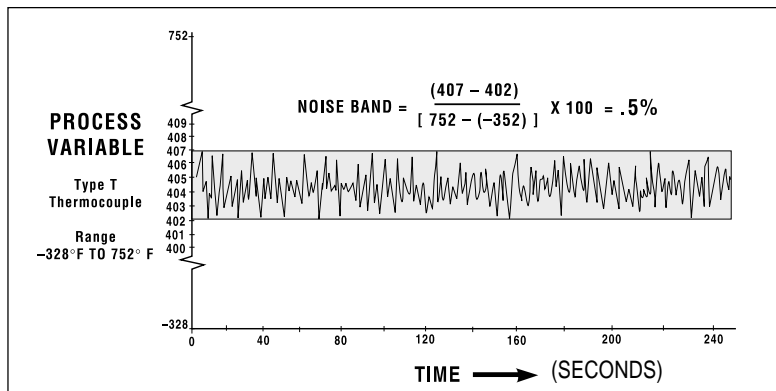


Fig. 7.12 Noise Band Calculation Example

### NOTE:

Adaptive tuning is **not** available for velocity position proportional control.

### CAUTION!

If the process conditions are temporarily changed, (e.g., during process shutdown, draining of a tank, etc.) **disable adaptive tuning**.

Otherwise, the controller will attempt to adapt its tuning parameters to the temporary process conditions.

Disable adaptive tuning by:

1. In the **TUNING** menu, change **ADAPTIVE** to **DISABLED** through the keypad; or
2. Closing the appropriate digital input (see Digital Input section in this chapter).



the process deviates from the setpoint due to noise in percentage of full scale.

Figure 7.13 shows a typical process variable response in a steady-state situation. In this example, the process noise is within a band of about 0.5% of full scale.

A noise band that is too small will result in tuning parameter values based on noise rather than the effects of load (and setpoint) changes. If the noise band is set too small, then Adaptive Tune will attempt to retune the controller too often. This may result in the controller tuning cycling between desirable system tuning and overly sluggish tuning. While the result may be better than that achieved with a non-adaptive controller, this frequent retuning is not desirable.

If the noise band is set too large, the process variable will remain within the noise band, and the controller will not retune itself. With too large a noise band, important disturbances will be ignored,

		INPUT TYPE										
		B	E	J	K	N	R/S	T	W/W/S	PLATINEL	RTD	0.1°RTD
Peak to Peak Noise °F	0	0.1%	0.1	0.1	0.1	0.1	0.1	0.1	0.1	0.1	0.1	0.1
	1	0.1	0.1	0.1	0.1	0.1	0.1	0.1	0.1	0.1	0.1	0.1
	2	0.1	0.1	0.1	0.1	0.1	0.1	0.2	0.1	0.1	0.1	0.2
	3	0.1	0.2	0.2	0.1	0.1	0.1	0.3	0.1	0.2	0.2	0.3
	4	0.1	0.2	0.2	0.1	0.1	0.1	0.4	0.1	0.2	0.2	0.5
	5	0.2	0.2	0.2	0.2	0.2	0.2	0.5	0.1	0.2	0.3	0.6
	6	0.2	0.3	0.3	0.2	0.2	0.2	0.6	0.1	0.3	0.3	0.7
	7	0.2	0.3	0.3	0.2	0.3	0.2	0.6	0.2	0.3	0.4	0.8
	8	0.2	0.4	0.4	0.3	0.3	0.3	0.7	0.2	0.4	0.4	0.9
	9	0.3	0.4	0.4	0.3	0.3	0.3	0.8	0.2	0.4	0.5	1.0
	10	0.3	0.4	0.4	0.3	0.4	0.3	0.9	0.2	0.4	0.5	1.1

Fig. 7.13 Noise Band Values for Temperature Inputs

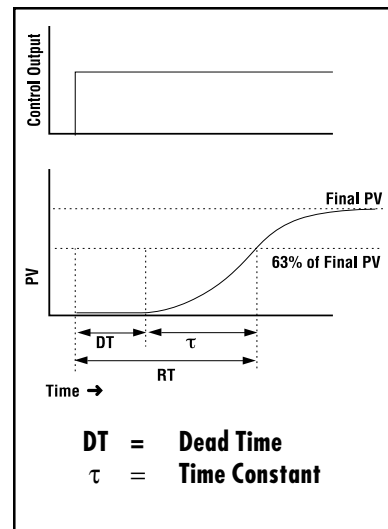


Fig. 7.14 Deadtime and Time Constant

and the controller will be indifferent to sluggish and oscillatory behavior.

Noise band settings are generally between 0.1% and 1.0%, with most common settings of 0.2% or 0.3%. *Figure 7.14* shows the conversion of peak-to-peak noise to an appropriate noise band for each T/C type & RTD.

### 3. Set **RESP. TIME**.

The response time is the most critical value in Adaptive Tuning. Response time represents the time lag from a change in valve position (controller output) to a specific amount of change in process variable. Specifically, Response Time is equal to the Deadtime of the process plus one Time Constant. The Deadtime is the time between initiation of an input change and the start of an observable response in the process variable. The Time Constant is the interval of time between the start of that observable response and the point where the process variable reaches 63% of its final value. (See *Figure 7.15*).

### **Example**

After a stimulus (e.g., valve movement), if it takes 300 seconds for a process to reach 63% of its new (expected) value, the response time is 300 seconds. If the response time is set too short, the process will be unstable and cycle around the setpoint. If the Response Time is set too long, response to an off-setpoint condition will be sluggish. It is generally better to use too long a response time than too short.

### **Self Tuning with Multiple Sets of PID**

For both Pretune and Adaptive Tune, the tuned set of PID is that which is active upon initiation of the tuning function.

The controller cannot trip to other PID sets (based on trip point or the digital input contact) until Adaptive Tuning is disabled. However, if the PID set is tied to the corresponding local setpoint, the active PID set values will change with the local setpoint.

Each PID set has 5 parameters that control its function—proportional band, reset, rate, manual reset (or loadline), and trip point. For each set (2 thru 8), these values have to be manually set.

1. Press MENU to access the **TUNING** menu.
2. Set values for parameters 1 thru 20 (these include the first PID set).
3. Press **MENU** to access these parameters for each additional PID set (2 through 8): **PROP. BND, RESET, RATE, MAN. RST.** and **TRIP**.

### Self Tune with Time Proportioning Outputs

When using either the Pretune or the Adaptive Tune with a time proportioning output, use as short of a cycle time as possible within the constraint of maintaining a reasonable life on relays, contacts or heating elements.

### Self Tune with Control Valves

In many systems utilizing a control valve, the point at which the control valve begins to stroke does not coincide with 0% output, and the point at which it completes its stroke doesn't coincide with 100%. The parameters **LOW OUT** and **HIGH OUT** in the **CONTROL** menu specify the limits on the output. Set these limits to correspond with the starting and stopping point of the valve's stroke. This prevents a form of "windup" and thus provides the adaptive control algorithm with the most accurate information.

For example, in manual the control output was slowly increased and it was noted that the control valve started to stroke at 18% and at 91% it completed its stroke. In this case **LOW OUT** should be set at 18% and **HIGH OUT** at 91%.

Note that when output limits are used, the full output range from -5 to 105% is available in manual control.

## J. RAMP-TO-SETPOINT

The DPC 535 contains a ramp-to-setpoint function that may be used at the user's discretion. This function is especially useful in processes where the rate-of-change of the setpoint must be limited.

When the ramping function is activated, the controller internally establishes a series of setpoints between the original setpoint and the new **target** setpoint. These interim setpoints are referred to as the **actual** setpoint. Either setpoint may be viewed by the user. When the setpoint is ramping, RAMPING will be shown in the 3rd display when the actual (ramping) setpoint is displayed.

When the target setpoint is being shown, RAMPING will **not** appear. Pressing the **DISPLAY** key will scroll the 2nd display as follows:

- From the target setpoint to the actual (ramping) setpoint;
- To the deviation from setpoint;
- To the output level; and
- Back to the target setpoint.

Note that when ramping, the deviation indication is with respect to the target setpoint.

The ramp-to-setpoint function is triggered by one of three conditions:

1. Upon power up, if the DPC 535 powers up in automatic control, then the setpoint will ramp from the process variable value to the setpoint value at the specified rate.
2. On a transfer from manual to automatic control the setpoint will ramp from the process variable value to the setpoint value at the specified rate.
3. On any setpoint change, the setpoint will ramp from the current setpoint to the new target setpoint. When triggered, the display will automatically change to indicate the ramping setpoint.

### **Software Configuration**

1. Go to the **PV INPUT** menu.
2. Set the **SP RAMP** parameter to the desired rate of change.

## **K. INPUT LINEARIZATION**

### **Thermocouple and RTD Linearization**

For a thermocouple or RTD input, the incoming signal is automatically linearized. The DPC535 has lookup tables that it uses to provide an accurate reading of the temperature being sensed.

### **Square Root Linearization**

Many flow transmitters generate a nonlinear signal corresponding to the flow being measured. To linearize this signal for use by the DPC 535, the square root of the signal must be calculated. The DPC 535 has the capability to perform this square root linearization.

For the first 1% of the input span, the input is treated in a linear

$$PV = \text{Low Range} + [(\text{Hi Range} - \text{Low Range}) \sqrt{(V_{\text{input}} - V_{\text{low}}) / (V_{\text{high}} - V_{\text{low}})}]$$

**Hi Range** is the high end of the process variable.

**Low Range** is the low end of the process variable.

$V_{\text{input}}$  is the actual voltage or current value of the input.

$V_{\text{high}}$  is the high end of the input signal range (e.g. 5 volts or 20 mA).

$V_{\text{low}}$  is the low end of the input signal range (e.g. 1 volt or 4 mA).

**Example:**

PV range is 0 – 1000.

Input signal range is 1–5 volts.

Input signal is 3 volts.

Therefore  $PV = 0 + [(1000 - 0) \sqrt{(3-1) / (5-1)}] = 1000 \sqrt{.5} = 707$

### Fig. 7.15 Square Root Linearization Formula

fashion. Then it is a calculated value, using the formula in Figure 7.16.

#### Hardware Configuration

- A voltage or milliamp input must be installed on the controller.

#### Software Configuration

1. Go to the **PV INPUT** menu.
2. Set **LINEARIZE** to SQR. ROOT.

#### Custom Linearization

Custom linearization allows virtually any nonlinear signal to be linearized using a 15-point straight line approximation curve (see Figure 7.17). Typical applications are linearizing signals from nonlinear transducers, or controlling volume based on level readings for irregularly-shaped vessels. To define the function, enter data point

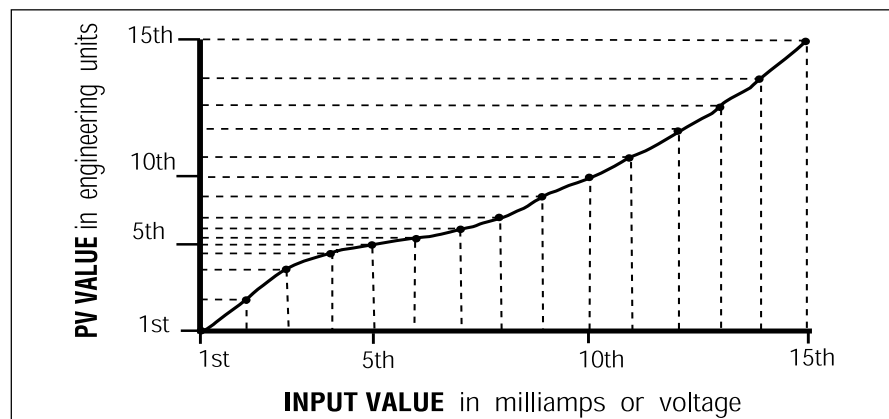


Fig. 7.16 15-point Linearization Curve

pairs—the engineering units corresponding to a particular voltage or current input.

### Software Configuration

1. Go to the **PV INPUT** menu.
2. Set the parameter **LINEARIZE** to CUSTOM.
3. Go to the **CUST. LINR.** menu.
4. Enter values for the **IST INPUT** and **IST PV** data points. All the input parameters define the actual milliamp or voltage input. All the PV parameters define the corresponding process variable value in engineering units.

**It is not necessary to use all 15 points.** Whenever the **XTH INPUT** becomes the high end of the input range, that will be the last point in the table.

Once the various points are defined, the values between the points are interpolated using a straight line relationship between the points. The only limitation is that the resulting linearization curve must be either ever-increasing or ever-decreasing.

## L. LOAD LINE

Load line is a manual reset superimposed on the automatic reset action. Adjusting the **MAN. RST.** tuning constant shifts the controller proportional band with respect to the setpoint.

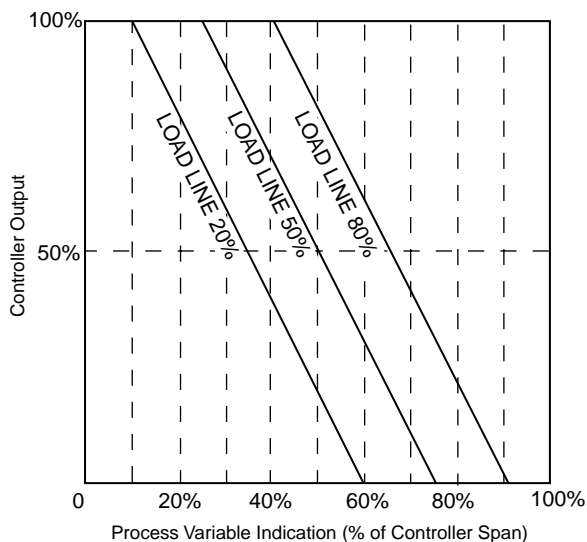


Fig. 7.170 Load Line Example

When used with a proportional only or proportional/derivative control algorithm, the **MAN. RST.** parameter (located in the **TUNING** menu) is in effect “manual reset”.

However, when the automatic reset term is present, the reset action gradually shifts the proportional band to eliminate offset between the setpoint and the process. In this case, load line provides an initial shift at which the reset action begins. Load line is adjusted by observing the percent output required to control the process and then adjusting the load line to that value. This minimizes the effect of momentary power outages and transients. Load line may also be adjusted to give the best response when bringing the load to the desired level from a “cold” start.

## M. SECURITY

The DPC 535 security system is easily customized to fit a system's needs.

### Software Configuration

1. Go to the **SECURITY** menu.
2. **SEC. CODE** defines the security password (range from -9999 to 99999). The rest of the security parameters can be selectively locked out.
3. **SP ADJUST** prevents the operator from using the ▲ and ▼ and keys to change the setpoint value. It does not prevent the operator from changing setpoints via the **SET PT** key.
4. **AUTO./MAN.** locks out the **MANUAL** key preventing the operator from transferring between automatic control and manual control.
5. **SP SELECT** locks out the **SET PT** key. This prevents the operator from changing among the various local setpoints or changing to remote setpoint. It does not prevent the operator from changing the setpoint value via the ▲ and ▼ keys.
6. **ALARM ACK.** locks out the **ACK** key, preventing an operator from acknowledging any alarms.
7. **TUNING** locks out modification to the parameters in the **TUNING** menu, preventing unauthorized changes to the tuning parameters or the activation/deactivation of the self tuning algorithm.
8. **CONFIGURE** allows access to the configuration menus, but prevents any unauthorized changes to the configuration parameters. If locked out, the security code is not accessible.

**NOTE:**  
**SEC CODE** does not appear unless all functions are unlocked.

**NOTE:**  
Lock out **CONFIGURE** for full security. If left unlocked, the operator will have access to the security code.

**NOTE:**  
The security function is compromised if the security code is left at zero (0).

## Basic Operating Procedures

The security feature can be overridden. When a locked function is attempted, the operator will have the opportunity to enter the security code. **If the correct security code is entered, the operator has full access. The security feature is reactivated after one minute of keypad inactivity.** If the security code is forgotten, the security feature can still be overridden.

- The security override code is **62647** .

Store this number in a secure place and blacken out the code in this manual to limit access.

## N. RESET INHIBITION

Reset Inhibition is useful in some systems either at the start-up of a process or when a sustained offset of process variable from setpoint exists. In conditions like these, the continuous error signal may cause the process temperature to greatly overshoot setpoint. Any of the digital inputs may be set up so that the contact closure disables the reset action (sets it to zero).

### Software Configuration

1. Go to the **CONFIG.** menu.
2. Set corresponding parameter(s) **CONTACT:I** to **CONTACT:5** to RST. INHBT.

## O. PROCESS VARIABLE READING CORRECTION

Conditions extraneous to the controller—and aging thermocouple, out of calibration transmitter, lead wire resistance, etc.—can cause the display to indicate a value other than the actual process value. The PV OFFSET and PV GAIN parameters can be used to compensate for these extraneous conditions. NOTE: This feature is provided as a convenience only. Correcting the cause of the erroneous reading is recommended.

1. Go to the **PV INPUT** menu.
2. Set **PV OFFSET**. This parameter either adds or subtracts a set value from the process variable reading in engineering units. For example, if the thermocouple was always reading 3° too high, the parameter could be set to “-3” to compensate.

### NOTE:

Security does not prevent the operation from the digital inputs or serial communications.



**NOTE:**

**PV GAIN** is only available if using a linear voltage or current input.

3. Set **PV GAIN**. This multiplies the deviation from the low end of the process variable range by the gain factor and then adds it to the value of the low end of the range to arrive at the adjusted process variable value.

For example, if the process variable range is 50 to 650 and the process variable reading is 472, a **PV GAIN** of .995 would yield an adjusted process variable equal to  $[(472 - 50) \times .995] + 50 = 470$ .

With a combination of both offset and gain factors, just about any inaccuracy in the sensor or transmitter can be compensated.

## P. SERIAL COMMUNICATIONS

The serial communications option enables the DPC 535 to communicate with a supervisory device, such as a personal computer or programmable logic controller.

The communications standard utilized is RS-485 which provides a multi-drop system that communicates at a high rate over long distances. Typical limitations are 32 instruments per pair of wires over a distance up to 4000 feet.

The DPC 535 uses a proprietary protocol which provides an extremely fast and accurate response to any command. Cyclic redundancy checking (CRC) virtually ensures the integrity of any data read by the DPC 535. Through communications, there is access to every Set up, Tuning and Operating parameter. For details on the DPC 535 protocol, contact a Dynisco application engineer at 1-800-221-2201.

### Hardware Configuration

- This optional features is only available if ordered originally from the factory. The circuitry for communications is contained on a modular circuit board that plugs into the Microcontroller Circuit Board, Refer to the order code in Chapter 1 for details.

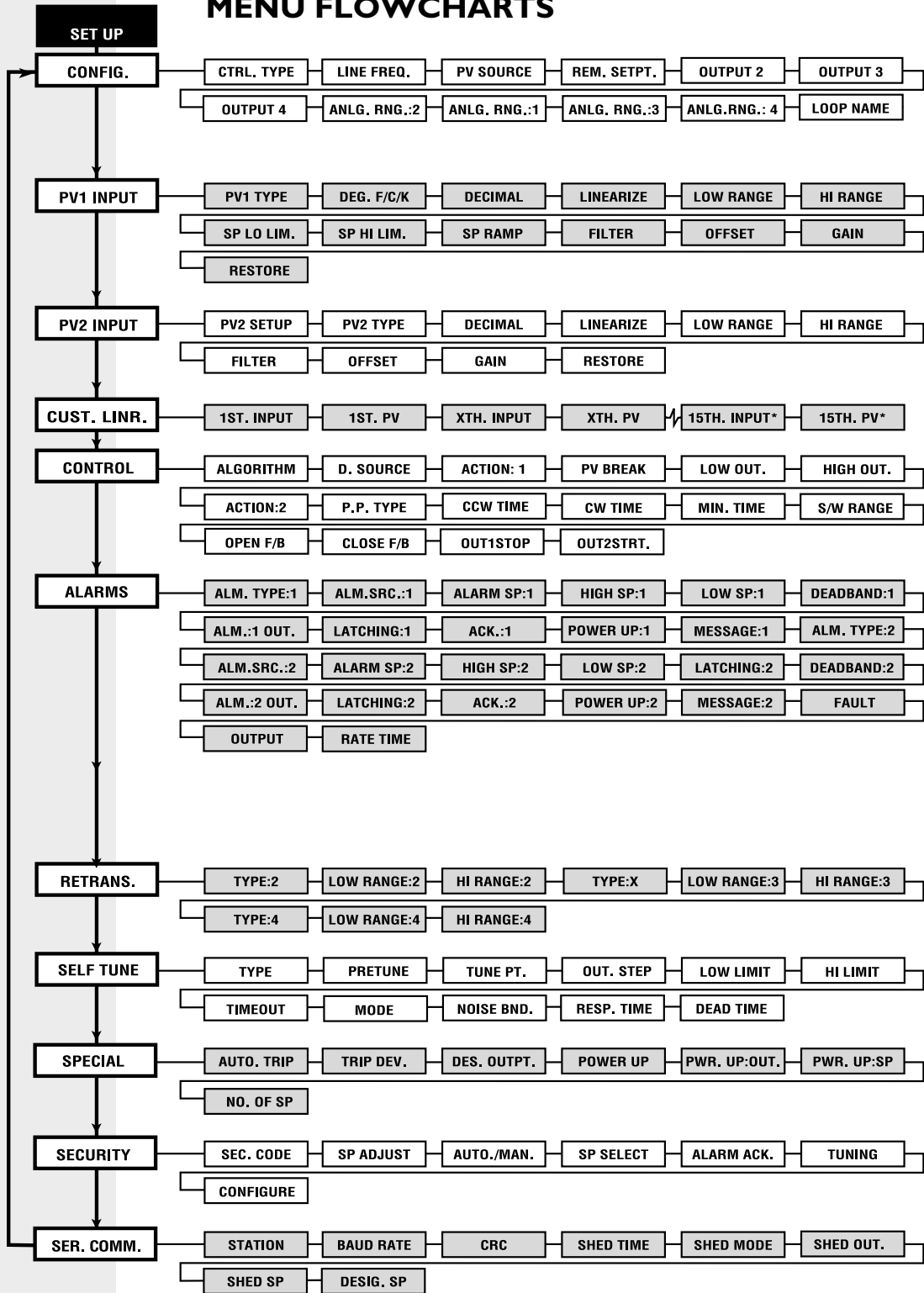
### Software Configuration

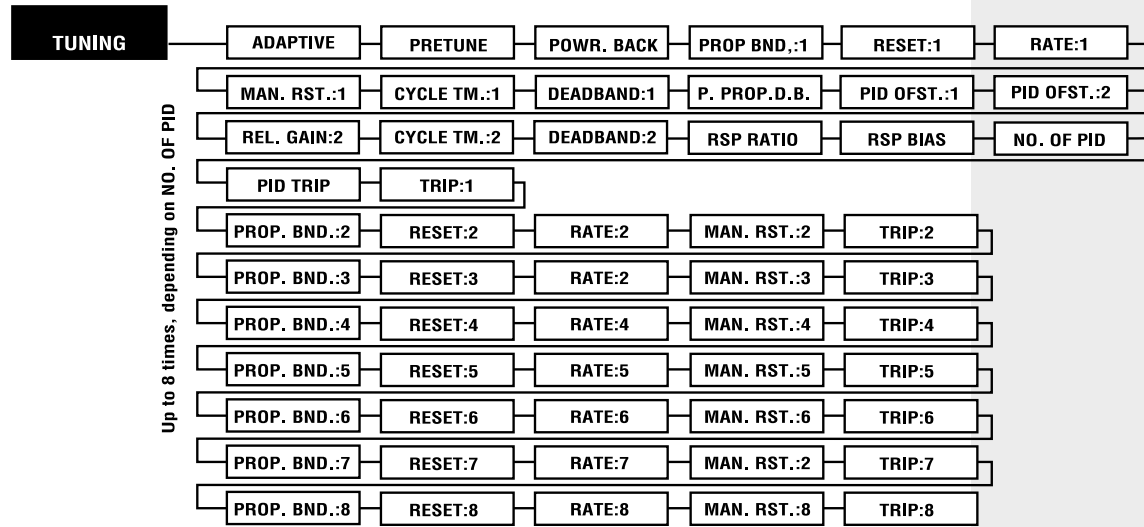
1. Access the **SER. COMM.** menu.
2. **STATION** specifies the unit's station address. It is the only way one DPC 535 can be distinguished from another. Each DPC 535 on the same RS-485 interface must have a unique station address.
3. Choose a **BAUD RATE** from 1200 to 19,200. In general, select the highest value. However, every instrument on the RS-485 interface must be set to the same baud rate.

4. **CRC** indicates the cyclic redundancy checking feature. If the host supports it, activating this option is recommended.
5. When the DPC535 senses that communications is lost, it can go to a predetermined state (called “shedding”). The **SHED TIME** parameter sets the length of time that communications can be interrupted before the controller sheds. Since the DPC535 is a stand-alone controller, it does not depend on communications to operate. Therefore, if the “shed” feature is not needed, set it to OFF.
6. **SHED MODE** designates the mode to which the controller goes after it sheds. Setting this to MANUAL brings up the following parameters.
7. Use **SHED OUT** to specify an output level if the unit sheds and trips to manual control.
8. To specify a control setpoint (in case the host is supervising the setpoint) if the DPC 535 sheds.; Set **SHED SP** to DESIG. SP and then, set the parameter **DESIG. SP** to the desired setpoint.

# APPENDIX I

## MENU FLOWCHARTS





## APPENDIX 2

### TROUBLESHOOTING

SYMPTOM	PROBLEM	SOLUTION
<b>Display will not light up</b>	Defective power source	Check power source and wiring
	Improper wiring	Correct wiring
	Blown in-line fuse	Check wiring, replace fuse
	Unit not inserted in case properly; or, screws have not been tightened.	Remove unit from case (and remove bezel screws), then reinsert unit and properly tighten screws.
<b>Improper/Lost PV reading</b> • Voltage/current	Input jumper selection improperly set	Move jumper to proper location
	Input range improperly selected in software	Select proper range
	Reverse polarity	Check and correct sensor wiring
	If controller powered, improperly wired	Check and correct wiring
	Loop power module not installed	Install module
	Defective transmitter	Replace transmitter
	Transmitter signal out of range	Select proper range in software
<b>Improper/Lost PV reading</b> • Thermocouple	Defective thermocouple	Replace thermocouple
	Input jumper selection improperly set	Select Proper input
	Wrong TC type selected in software	Select proper thermocouple type in software
	Improper wiring	Wire properly
<b>Improper/Lost PV reading</b> • RTD	Defective RTD	Replace RTD
	Input jumper selection improperly set	Move jumper connector to proper location
	Improper wiring	Wire properly
<b>No control output</b>	Output wiring and module location do not match	Check and correct wiring or module location
	If SSR, SSR Drive of Milliamp output, jumpers J1, J2 and J3 are not set properly	Set jumper connector to proper location
	Software configuration does not match hardware	Reconfigure software to match hardware
	PID values not set properly	Set PID values properly
<b>Can't switch to auto control</b>	Input sensor signal is not connected or valid	See PV LOST message
<b>Erratic display</b>	Resetting action due to electrical noise on powerline	Filter power line.
	PID values not set properly	Retune controller

<b>Message</b>	<b>When does it occur?</b>	<b>What to do:</b>
<b>DEFAULTS</b>	Whenever the memory is cleared and all parameters revert to factory default settings. This may be done by purposely clearing the memory or when the unit is powered up for the first time or if the software version is changed.	Entering the Set Up mode and changing a parameter will clear the message. If due to something other than the user purposely clearing the memory, call factory for assistance.
<b>LOST CAL. or ERROR: BAD CAL. DATA</b>	Indicates that the calibration data has been lost. Occurs if all the memory has been erased.	Problem should never happen. Must correct the situation and recalibrate. Call factory for assistance.
<b>PV1 UNDER or PV1 OVER or PV2 UNDER or PV2 OVER or</b>	When the process variable value travels slightly outside the boundaries of the instrument span. Does not apply to thermocouple or RTD inputs.	May not need to do anything. May want to check the transmitter accuracy and check to see if range of transmitter matches the range of the controller.
<b>LOST PV1 or LOST PV2</b>	When the controller senses a lost process variable signal or the input signal travels well beyond the instrument span.	Check wiring and sensor/transmitter.
<b>COMM SHED</b>	When the communications is lost for longer than the communications shed time.	Check communications wiring, etc. To clear message, must make an auto/manual change.
<b>ERROR: ROM CHECKSUM</b>	On power up a problem with the EPROM is detected. Controller locks up until fixed.	This is a fatal error and requires an EPROM change. Call factory for assistance.
<b>OUT1 CONF or OUT2 CONF</b>	Upon power up, controller senses that the modules needed for control as determined by software configuration are not present.	Must power down and install correct module combination or must reconfigure the controller to match the current module combination.
<b>LOST F/B</b>	The slidewire feedback is sensed as lost.	Check the slidewire wiring.
<b>LOST CJC</b>	The cold junction is sensed as lost.	Call factory for assistance.
<b>ERROR: BAD EEPROM</b>	During power up an EEPROM failure is detected. Controller locks up until fixed.	This is a fatal error and requires an EPROM change. Call factory for assistance.
<b>NEEDS CAL.</b>	When the controller is powered up with default calibration data (input and output accuracy specifications may not be met).	Enter calibration menu and recalibrate the controller. Call factory for assistance.
<b>ERROR: BAD MODEL NUM.</b>	During power up, a discrepancy was found between the EEPROM's and controller's model numbers. Controller locks up until fixed.	This is a fatal error and requires an EPROM or EEPROM change. Call factory for assistance.
<b>CAL.ERROR SEE.MANUAL</b>	During cold junction calibration, a discrepancy was found between the controller type and the case type.	Install the 535 chassis into the actual case with which it was shipped, then run calibration again. If further problems, call factory for assistance.

## APPENDIX 3

### SPECIFICATIONS

Accuracy	Typical	Maximum
<b>LINEAR</b> (Voltage)	$\pm 0.025\%$ of full scale	$\pm 0.100\%$ of full scale
(Current)	$\pm 0.050\%$ of full scale	$\pm 0.150\%$ of full scale
<b>RTD</b> 1°	$\pm 0.050\%$ of span	$\pm 0.150\%$ of span
0.1°	$\pm 0.095\%$ of span	$\pm 0.225\%$ of span

#### THERMOCOUPLE

J, K, N, E (> 0°C)	$\pm 0.060\%$ of span	$\pm 0.150\%$ of span
J, K, N, E (< 0°C)	$\pm 0.150\%$ of span	$\pm 0.375\%$ of span
T (> 0°C)	$\pm 0.100\%$ of span	$\pm 0.250\%$ of span
T (< 0°C)	$\pm 0.250\%$ of span	$\pm 0.625\%$ of span
R, S (> 500°C)	$\pm 0.150\%$ of span	$\pm 0.375\%$ of span
R, S (< 500°C)	$\pm 0.375\%$ of span	$\pm 0.925\%$ of span
B (> 500°C)	$\pm 0.150\%$ of span	$\pm 0.375\%$ of span
B (< 500°C)	$\pm 0.500\%$ of span	$\pm 1.000\%$ of span
W, W5 & Platinel II	$\pm 0.125\%$ of span	$\pm 0.325\%$ of span

Display accuracy is  $\pm 1$  digit. These accuracy specifications are at reference conditions (25°C) and only apply for NIST ranges. Detailed accuracy information is available upon request.

#### CONTROL ALGORITHM

PID, P with manual reset, PI, PD with manual reset, and On-Off are selectable from the front panel. Duplex outputs each use the same algorithm, except On-Off may be used with PID. The PID algorithm used is non-interacting.

#### Tuning Parameters

**Proportional Band:** 0.1 to 999% of input range

**Integral:** 1 to 9999 seconds/repeat

**Derivative:** 0 to 600 seconds

**Manual Reset/Load Line:** 0 to 100% output

**Cycle Time:** 0.3 to 120 seconds

**On-Off Deadband:** up to 15% of input range (in eng. units)

Up to eight sets of PID values may be stored in memory and selected automatically, based on setpoint value, process variable value, or the corresponding local setpoint (SP1–SP8).

## SELF TUNING OF PID VALUES

**POWERTUNE® On-demand “pretune”:** This is an open loop algorithm that may be used on its own to calculate PID variables, or it can be used to provide preliminary PID values, as well as process identification information to be used by the adaptive tune.

Three pretune types are available: TYPE 1 for slow thermal processes; TYPE 2 for fast fluid or pressure applications; and TYPE 3 for level control applications.

**Adaptive tune:** Our exclusive POWERTUNE® adaptive tuning algorithm automatically adjusts the PID values whenever a process upset occurs. Preliminary information may be input manually or automatically calculated by our pretune algorithm.

## OVERSHOOT PROTECTION

POWERBACK is Dynisco's proprietary, user-invoked, setpoint overshoot protection algorithm. When invoked, POWERBACK reduces or eliminates setpoint overshoot at power up or after setpoint changes. POWERBACK monitors the process variable to make predictive adjustments to the control parameters, a feature that helps eliminate overshoot of setpoint.

## ISOLATION

Inputs and outputs are grouped into the following blocks:

- Block 1:** process variable
- Block 2:** outputs 1, 2, and 4
- Block 3:** communications, output 3 (Earth Ground)

Each block is electrically isolated from the other blocks to withstand a HIPOT potential of 500 Vac for 1 minute or 600 Vac for 1 second, with the exception of blocks 1 and 4, which are isolated to withstand a HIPOT potential of 50 volts peak for 1 minute between each other. Inputs and outputs are not isolated from other inputs and outputs within the same block.

## CONTROLLER ARCHITECTURE

The DPC 535 Controller hardware can be configured as follows:

Inputs: Two universal process variable inputs are standard.

Outputs: Four outputs are available. See Ordering Information.

RS-485 Communications: Available as option with any configuration.

## PROCESS VARIABLE INPUTS - 2 PROCESS VARIABLES AVAILABLE

Universal input type. Any input type may be selected in the field. Selection of input type (thermocouple, RTD, voltage or current) via jumper. Selection of particular sensor or range is via front panel.

THERMOCOUPLES	RANGE °F	RANGE °C
B	104 to 3301	40 to 1816
E	-454 to 1832	-270 to 1000
J	-346 to 1832	-210 to 1000



K	-418 to 2500	-250 to 1371
N	-328 to 2372	-200 to 1300
R	32 to 3182	0 to 1750
S	32 to 3182	0 to 1750
T	-328 to 752	-200 to 400
W	32 to 4172	0 to 2300
W5	32 to 4172	0 to 2300
Platinel II	-148 to 2550	-100 to 1399

<b>RTDs</b>	<b>RANGE °F</b>	<b>RANGE °C</b>
100ΩPt. (DIN)	-328 to 1562	-200 to 850
	-328.0 to 545.0	-200.0 to 285.0
100ΩPt. (JIS)	-328 to 1202	-200 to 650
	-328.0 to 545.0	-200.0 to 285.0
100ΩPt. (SAMA)	-328 to 1202	-200 to 650
	-328.0 to 545.0	-200.0 to 285.0

<b>TRANSMITTER SIGNALS</b>	<b>INPUT RANGE</b>
Milliamps DC	4 to 20
	0 to 20
Voltage DC	1 to 5
	0 to 5
Millivolts DC	0 to 10
	0 to 30
	0 to 60
	0 to 100
	-25 to 25

**STRAIN GAGE**

3.33 mV/V

**LINEARIZATION**

Thermocouple and RTD inputs are automatically linearized. Transmitter inputs may be linearized with a square root function or user-defineable 15-point straight line linearization function.

**INPUT IMPEDANCE**

**Current Input:** 250 Ω  
**Voltage Input:** 1 MΩ

**Thermocouples:** 10 MΩ  
**RTDs:** 10 MΩ

## **UPDATE RATE**

Input is sampled and output updated 10 times per second. Display is updated five times per second.

## **TRANSMITTER LOOP POWER**

Isolated 24 Vdc (nominal) loop power supply is available if a loop power module is installed in an output socket not used for control. Capacity is 25 mA.

## **INPUT SIGNAL FAILURE PROTECTION**

When input is lost, output is commanded to a predetermined output (–5 to 105%). Thermocouple burnout is selectable for upscale or downscale.

## **INPUT FILTER**

Single pole lowpass digital filter with selectable time constant from 0 to 120 seconds.

## **CALIBRATION**

Comes fully calibrated from the factory and continuously calibrates itself for component aging due to temperature and time, except for the reference voltage. Field calibration can be easily performed in the field with a precision multimeter and thermocouple simulator. Process variable offset and gain factors are provided to correct for sensor errors.

## **OUTPUT MODULES**

The controller can have a total of four control outputs, alarm outputs and/or loop power modules installed. There are five types of output modules which can be configured to suit your particular application. The modules may be ordered factory-installed, or they may be installed in the field.

**Analog module:** Either 0–20 mA or 4–20 mA (front panel selectable) into a load up to 1000 $\Omega$ . Accuracy  $\pm 5\mu\text{A}$  @ 25°C.

**Mechanical relay module:** SPDT electromechanical relay. Resistive load rated at 5 amps at 120/240 VAC. Normally open or normally closed selection is made by jumper. Output 4 is rated at 0.5 amps at 24 VAC and is always normally open.

**Solid state relay (triac) module:** Resistive load rated at 1 amp at 120/240 VAC. Output 4 is rated at 0.5 amps at 24 VAC. These outputs are normally open.

**DC logic (SSR drive) module:** “ON” voltage is 17 Vdc (nominal). “OFF” voltage is less than 0.5 Vdc. (Current limited to 40mA.)

**Loop power supply module:** Current is limited to 25 mA @ 24V (nominally loading).

**Strain Gage Excitation:** 10V + 2% into min 175 ohms

## **CONTROL OUTPUTS**

Up to two output modules may be designated for control. Any combination of output modules, with the exception of the loop power supply module, may be used.

Duplex control is available if output modules are installed in the first and second output sockets.

**Staged (split range) outputs** are available if analog modules are installed in the first and second output sockets. This algorithm will allow the output range to be split between the two outputs.

### **RETRANSMISSION OUTPUT**

Based on available outputs (any socket not used for control), up to two different variables can be simultaneously programmed for retransmission. Each precise, 16-bit resolution output may be scaled for any range. Variable selection includes: PV, SP, RAMP SP, and OUTPUT.

### **ALARMS**

The DPC 535 controller has two software alarms. High and low alarms may be sourced to the PV, SP, RAMP SP, DEVIATION and OUTPUT. If an alarm is tripped, the alarm message will show, the ACK key will illuminate (if acknowledgeable) and the ALM icon will light. If the alarm is tied to the first available non-control output, the "1" below the ALM icon will light. Similarly, if the alarm is tied to the second non-control output, the "2" below the ALM will light. The availability of outputs determines how many alarms can be tied to relays.

Up to two alarm outputs are available if an associated mechanical, solid state relay or DC logic module is installed in any output socket not used for control.

Global Alarm feature allows one or more of the internal software alarms to be tied to the same single, physical output. The acknowledge key is active for alarms associated with either loop.

### **SERIAL COMMUNICATIONS**

Isolated serial communications is available using an RS-485 interface. Baud rates of up to 19,600 are selectable. The protocol supports CRC data checking. If communications is lost, a time-out feature will command the controller to a particular control mode and specific setpoint or output if desired. Outputs 2–4 and digital inputs can act as "host-controlled" I/O independent of the controller's function. The PV may be sourced via this interface. May be installed in the field.

### **DIGITAL DISPLAYS**

Upper display: five-digit, seven-segment. Used exclusively for displaying the process variable value. Height is 15 mm (0.6 in.).

2nd display: nine-character, 14-segment alphanumeric. Used for displaying setpoint, deviation, output value, slidewire position (actual valve position) and configuration information. Height is

6 mm (0.25 in.).

3rd display: nine-character, 14-segment alphanumeric. Used for indicating which loop is displayed and for displaying alarm messages and configuration information. Height is 6 mm (0.25 in.).

All displays are vacuum fluorescent. Color is blue-green.

## **STATUS INDICATORS**

There are two types of indicators: icons and illuminated keys.

**ALM 1 and ALM 2 icons:** alarm 1 and alarm 2 status.

**OUT 1 and OUT 2 icons:** control output 1 and control output 2 status.

**MAN key illuminated:** controller is in manual control mode.

**ACK key illuminated:** alarm may be acknowledged.

**SET PT key illuminated:** setpoint other than primary local setpoint is active.

**MENU key illuminated:** controller is in configuration mode.

## **DIMENSIONS**

Meets 1/4 DIN designation as specified in DIN standard number 43 700.

See diagram for details.

## **MOUNTING**

Panel-mounted.

## **WIRING CONNECTIONS**

29 screw terminals in the rear of the instrument.

## **POWER CONSUMPTION**

15 VA at 120 VAC, 60 Hz (typical).

## **WEIGHT**

Approximately 1 kg (2.2 lbs.).

## **AMBIENT TEMPERATURE**

Operative Limits: 0 to 50°C (32 to 122°F).

Storage Limits: -40 to 70°C (-40 to 158°F).

## **RELATIVE HUMIDITY**

10 to 90%, non-condensing.

## **VOLTAGE AND FREQUENCY**

Universal power supply: 90 to 250 VAC, 48 to 62 Hz.

## **NOISE IMMUNITY**

Common mode rejection (process input): > 120 dB.

Normal mode rejection (process input): > 80 dB.

AC line is double filtered and transient protected. Snubbers are provided for each relay output.

## **CONSTRUCTION**

Case: extruded, non-perforated ABS plastic.

Bezel: black plastic ABS.

Chassis assembly: plug-in type.

Keys: silicone rubber with diffusion printed graphics.

NEMA rating: front panel conforms to NEMA 4X when instrument is properly installed.

## **AGENCY APPROVALS**



LR 84603



LISTED  
Process Control Equipment  
4N66



(Heavy Industrial)

(Available as an option)

## **MEMORY RETENTION**

Lithium battery maintains all programming for approximately ten years.

## **SECURITY**

There are two levels of access: restricted and full. A configurable code is used to enter the full access level. Functions not available in the restricted level are configurable.

## APPENDIX 4

### GLOSSARY

**adaptive control:** Control in which automatic means are used to change the type or influence (or both) of control parameters in such a way as to improve the performance of the control system.

**adaptive tune:** A component of the 535 self tune function which continuously monitors the process and natural disturbances and makes adjustments in the tuning parameters to compensate for or improve the performance of the control system.

**alarm:** A condition, generated by a controller, indicating that the process has exceeded or fallen below the set or limit point.

**alarm, band:** A type of alarm set up where a band is created around the control setpoint.

**alarm, deviation:** An alarm similar to a band alarm except it only creates a band on one side of the alarm setpoint.

**alarm, fault:** An indication that becomes active upon loss of process variable. Fault alarm operates in addition to other alarm assignments.

**alarm, global:** The single physical output to which one or more internal software alarms are tied.

**alarm, high process variable:** A type of alarm that is set up to occur when the process variable goes above the alarm setpoint.

**alarm, low process variable:** A type of alarm that is set up to occur when the process variable goes below the alarm setpoint.

**alarm, manual:** A type of alarm set up to occur when the controller is put into manual mode of operation.

**alarm, power up:** A type of alarm that determines alarm condition on power up of the controller.

**alarm, rate-of-change:** A type of alarm set up to occur when there is an excessive change in the process variable (PV) value.

**baud rate:** Any of the standard transmission rates for sending or receiving binary coded data.

**bezel:** The flat portion surrounding the face of the controller, which holds the keys and display.

**bump:** A sudden increase in the output power initiated by the controller in order to determine the system response during a self tune procedure.

**binary coded decimal (BCD):** A notation in which the individual decimal digits are represented by a group of binary bits, e.g., in the 8-4-2-1 coded decimal notation each decimal digit is represented by four binary bits.

**calibration:** The act of adjustment or verification of the controller unit by comparison of the unit's reading and standards of known accuracy and stability.

**cascade control:** Control in which the output of one controller is the setpoint for another controller.

**closed loop:** Control system that has a sensing device for process variable feedback.

**cold junction:** Point of connection between thermocouple metals and the electronic instrument.

**configuration:** Also called "set up," selection of hardware devices and software routines that function together.

**cold junction compensation:** Electronic means used to compensate for the effect of temperature at the cold junction.

**contact:** In hardware, a set of conductors that can be brought into contact by electromechanical action and thereby produce switching. In software, a symbolic set of points whose open or closed condition depends on the logic status assigned to them by internal or external conditions.

**control action:** The slope of the output of the instrument in reference to the input, e.g., direct output increases on rise of input. Typical cooling response or reverse output decreases on rise of input (typical heating response).

**control action, derivative (rate) (D):** The part of the control algorithm that reacts to rate of change of the process variable.

**control action, integral (reset) (I):** The part of the control algorithm that reacts to offset between setpoint and process variable.

**control action, proportional (P):** Control action in which there is a continuous linear relation between the output and the input.

**control action, proportional plus derivative (PD):** A control algorithm that provides proportional control with the addition of derivative action to compensate for rapid changes in process variable.

**control action, proportional plus integral (PI):** A control algorithm that provides proportional control with the addition of integral action to compensate for offsets between setpoint and process variable.

**control action, proportional plus integral plus derivative (PID):** A control algorithm that provides proportional control with both integral and derivative action.

**control, adaptive:** (see adaptive control)

**control algorithm:** A mathematical representation of the control action to be performed.

**control, cascade:** (see cascade control)

**control output:** The end product which is at some desired value that is the result of having been processed or manipulated.

**control mode, automatic:** A user selected method of operation where the controller determines the control output.

**control mode, manual:** A user selected method of operation where the operator determines the control output.

**control parameters:** User defined values that specify how the process is to be controlled.

**controlled variable:** A process variable which is to be controlled at some desired value by means of manipulating another process variable.

**CRC (cyclic redundancy check):** An error checking technique in which a checking number is generated by taking the remainder after dividing all the bits in a block (in serial form) by a predetermined binary number.

**CSA:** Acronym for Canadian Standards Association.

**cycle time:** The time necessary to complete a full ON-through-OFF period in a time proportioning control system.

**damping:** The decrease in amplitude of an oscillation due to the dissipation of energy.

**damped, 1/4 amplitude:** The loss of one-quarter of the amount of amplitude with every oscillation.

**dead band:** A temperature band between heating and cooling functions; the range through which an input can be varied without initiating observable change in output.

**dead time:** The interval of time between initiation of an input change or stimulus and the start of the resulting observable response.

**default settings:** Parameters selections that have been made at the factory.

**derivative:** Anticipatory action that senses the rate of change of temperature, and compensates to minimize overshoot and undershoot. Also "rate."

**derivative action:** (See control action, derivative)

**deviation:** The difference between the value of the controlled variable and the value at which it is being controlled.

**digital input:** Used in this manual to indicate the status of a dry contact; also called "gate".

**DIN:** Deutsche Industrial Norms, a German agency that sets standard for engineering units and dimensions.

**display, 1st:** The top, largest display of controller face that is used to display the process variable value.

**display, 2nd:** The middle display of the controller face used to indicate: in **OPERATION** Mode - the setpoint, deviation or output; in **TUNING** or **SET UP** Mode - the parameter or parameter menu.

**display, 3rd:** The bottom display of the controller face that is used to indicate:

**Operation Mode** — alarm or error message; Tuning of Set up Mode — the value or choice of the parameter.

**disturbance:** An undesired change that takes place in a process that tends to affect adversely the value of a controlled variable.

**duty cycle:** Percentage of “load ON time” relative to total cycle time.

**earth ground:** A terminal used on the 535 to ensure, by means of a special connection, the grounding (earthing) of part of the controller.

**engineering unit:** Terms of data measurement such as degrees Celsius, pounds, grams, etc.

**feedback:** Process signal used in control as a measure of response to control action; the part of a closed-loop system which automatically brings back information about the condition under control.

**FM:** Factory Mutual Research Corporation; an organization which sets safety standards.

**gain:** The ratio of the change in output to the change in input which caused it.

**heat/cool control:** Control method where the temperature of the end product is maintained by controlling two final elements using two of the 535 outputs.

**hysteresis:** In ON/OFF control, the temperature change necessary to change the output from full ON to full OFF.

**hunting:** Oscillation or fluctuation of process temperature between setpoint and process variable.

**icons:** Indicators on the face of the controller.

**input:** Process variable information being supplied to the instrument.

**integral:** Control action that automatically eliminates offset, or “droop”, between setpoint and actual process temperature. Also “reset.”

**internal voltage reference:** A precision voltage source within the 535 controller, used to establish internal calibration.

**isolation:** Electrical separation of sensor from high voltage circuitry. Allows for application of grounded or ungrounded sensing element.

**offset:** Adjustment to actual input temperature and to the temperature values the controller uses for display and control.

**JIS:** Japanese Industrial Standards. Also Japanese Industrial Standards Committee (JISC). Establishes standards on equipment and components.

**jumper:** A wire that connects or bypasses a portion of a circuit on the printed circuit board.

**jumper connectors:** The connecting device that straddles a jumper to connect or bypass a portion of a circuit on a printed circuit board.

**linearization:** A function the 535 uses to automatically linearize a non-linear signal, either from thermocouple or RTD temperature sensors, through the use of look up tables. The relationship that exists between two variables when the ratio of the value of one variable to the corresponding value of the other is constant over an entire range of possibilities.

**linearization, custom:** User-definable linearization.

**linearization, square root:** A function the 535 uses to linearize a non-linear signal corresponding to the flow being measured by flow transmitters.

**load line out:** A start up output value which is to bring initial output closer to actual steady state output.

**loop power:** An internal 24-volt current limited power supply used to power 2 or 4 wire transmitter on the input of the controller.



**load:** The demand for input to a process.

**low pass input filter:** A method to block fast acting signals (typically noise), while allowing slow acting signals (actual process variable) to pass.

**manipulated variable:** A quantity or condition which is varied so as to change the value of the controlled variable. (see also control output)

**mechanical relay:** (see relay)

**menu:** (see menu block)

**menu block:** Groups of parameters arranged in the software.

**microcontroller:** A large scale integrated circuit that has all the functions of a computer, including memory and input/output systems.

**NEMA 4X:** A National Electrical Manufacturers Association standard for specifying a product's resistance to water and corrosion.

**normally open:** A switched output (i.e., relay, etc.) whose unpowered state has no connection.

**normally closed:** A switched output (i.e., relay) whose unpowered state provides connection.

**noise:** An unwanted component of a signal or variable.

**noise band:** A measurement of the amount of random process "noise" affecting the measurement of the process variable.

**offset:** The difference in temperature between the setpoint and the actual process temperature.

**ON/OFF control:** Control of temperature about a setpoint by turning the output full ON below setpoint and full OFF above setpoint in the heat mode.

**open loop:** Control system with no sensory feedback.

**optimization:** The act of controlling a process at its maximum possible level of performance, usually as expressed in economic terms.

**output modules:** Plug in devices that provide power handling to enable process control. These modules are either binary (on/off) such as a relay, or analog (continuously variable) for current loop control.

**output:** Action in response to difference between setpoint and process variable.

**overshoot:** Condition where temperature exceeds setpoint due to initial power up or process changes.

**P control:** Proportioning control.

**parameter(s):** A user-defined variable that specifies how a particular function in the 535 will operate.

**PD control:** Proportioning control with rate action.

**PI control:** Proportioning control with auto-reset.

**PID control:** Proportioning control with auto-reset and rate.

**position proportioning:** A type of control output that utilizes two relays to control an electric motorized actuator.

**pretune algorithm:** A method by which the 535 controller initiates an output value change, monitors the manner of the corresponding process variable change, and then determines the appropriate PID control parameters.

**primary loop:** The outer loop in a cascade system.

**process variable:** In the treatment of material, any characteristic or measurable attribute whose value changes with changes in prevailing conditions. Common variables are level, pressure and temperature.

**proportional band:** The change in input required to produce a full range change in output due to proportional control action.

**ramping:** (see setpoint, ramping)

**rate:** Anticipatory action that senses the rate of change of temperature and compensates to minimize overshoot. Also “derivative.”

**rate action:** The derivative function of a controller.

**rate time:** The time interval over which the system temperature is sampled for the derivative function.

**regulate:** The act of maintaining a controlled variable at or near its setpoint in the face of load disturbances.

**relay (mechanical):** An electromechanical device that completes or interrupts a circuit by physically moving electrical contacts into contact with each other.

**relay (solid state):** A solid state switching device which completes or interrupts a circuit electrically with no moving parts.

**reset:** Control action that automatically eliminates offset, or “droop,” between setpoint and actual process temperature. Also “integral.”

**reset term:** (see reset)

**RTD:** Resistance Temperature Detector. Resistive sensing device displaying resistance versus temperature characteristics. Displays positive temperature coefficient.

**relative gain:** An open-loop gain determined with all other manipulated variables constant, divided by the same gain determined with all other controlled variables constant.

**retransmission:** a feature on the 535 which allows the transmission of a milliamp signal corresponding to the process variable, target setpoint or actual setpoint to another devices, typically a chart recorder.

**sample interval:** The time interval between measurements or observations of a variable.

**secondary loop:** The inner loop of a cascade system.

**self tune:** A method of automatically calculating and inserting optimum PID parameters by testing system response and timing.

**serial communications:** The sending or receiving of binary coded data to a supervisory device such as a personal computer or programmable logic controller.

**setpoint:** An input variable which sets the desired value of a controlled variable.

**setpoint, actual:** The desired value of a controlled variable that the controller is currently acting upon.

**setpoint, deviation from:** The number of units difference between the current process variable and the setpoint.

**setpoint, ramping:** A setpoint which is determined by the ramp function of the controller where over time the controller variable reaches a desired value.

**setpoint, target:** The end point of the ramp function.

**set up:** Also called configuration, selection of hardware devices and software routines that function together.

**sheds:** In serial communications, when the signal is lost.

**slidewire position proportioning:** An output algorithm that utilizes a slidewire feedback signal to determine the actual position of the actuator being controller.

**solid state relay:** (see relay, solid state)

**SSR drive:** A D.C. on/off signal output for controlling a solid state relay.

**staged outputs:** The set up of two analog outputs, where one analog output varies its signal over a portion of the PID output range, and the second analog output then varies its signal over the remainder of the PID output range.

**static discharge:** Undesirable current resulting from the discharge of electrostatic energy.

**station address:** The unique identifier assigned to a device for communications.

**thermocouple:** Temperature sensing device that is constructed of two dissimilar metals wherein a measurable, predictable voltage is generated corresponding to temperature.

**thermocouple break protection:** Fail-safe operation that assures desired output upon an open thermocouple condition.

**thermocouple upscale burnout (▲):** Jumper position that determines whether, when a thermocouple fails, its output is replaced by a millivoltage which will match the thermocouple's maximum value. The jumper connector should be placed in the TC ▲ position.

**thermocouple downscale burnout (▼):** Jumper position that determines whether, when a thermocouple fails, its output is replaced by a millivoltage which will match the thermocouple's minimum value. The jumper connector should be placed in the TC ▼ position.

**three mode control:** (See control action PID)

**time proportioning control:** A control algorithm that expresses output power (0–100%) as a function of percent ON versus percent OFF within a preset cycle time.

**time proportioning output:** A controller output assigned by software to facilitate time proportional control (typically a relay, SSR, or SSR Drive output).

**tracking:** A function that defines whether the local setpoint will track the remote setpoint. When the controller is transferred to a local setpoint, that local setpoint value will match the remote process value when the transfer occurs.

**transmitter (2-wire):** A device used to transmit data via a two wire current loop. A two-wire transmitter is loop powered.

**transmitter (4-wire):** A device used to transmit data via a current loop or a DC voltage. A 4-wire transmitter uses 2 wires for data and 2 wires for power.

**triac:** Solid state switching device used to switch alternating current signals on and off. Triac circuits are sometimes referred to as solid state relays (SSR).

**trip point:** Value which determines when that set of PID values becomes active.

**velocity position proportioning:** This is a control technique where valve position is determined by calculating the amount of time it takes to open/close a valve by moving the valve for a portion of that time.

**windup:** Saturation of the integral mode of a controller developing during times when control cannot be achieved, which causes the controlled variable to overshoot its setpoint when the obstacle to control is removed.

**wild stream:** In mixing applications that require materials to be mixed to a desired ratio, this is the one part of the material that is uncontrolled.

— NOTES —

## **WARRANTY AND SERVICE**

This equipment is sold subject to the mutual agreement that it is warranted to be free from defects of material and construction but our liability in connection with it shall be limited to repairing or replacing without charge at our factory any material or construction defects which become apparent within one year from the date on which the equipment is shipped, that we have no liability for damages of any kind arising from the installation and/or use of this equipment by anyone and that the purchaser by the acceptance of this equipment will assume all liability for any damages which may result from its misuse by the purchaser, his or its employees or by others. There is no guarantee or warranty or liability except as here stated.

Should the equipment require service or repair, please return it, along with a brief description of the problem(s) encountered, freight prepaid to:

**Dynisco Instruments  
38 Forge Parkway  
Franklin, MA 02038  
Attention: Service Department**

**NOTE:** Before returning any product for repair, please call the Dynisco Service Department at (508) 541-9400 or (800) DYNISCO or E-mail: [repair@mc.dynisco.com](mailto:repair@mc.dynisco.com) for a Return Authorization number.

**FOR  
TECHNICAL  
ASSISTANCE  
CALL  
1-800-221-2201**



## WARRANTY REGISTRATION CARD

MODEL NUMBER \_\_\_\_\_

SERIAL NUMBER \_\_\_\_\_

DATE PURCHASED \_\_\_\_\_

PURCHASED FROM: \_\_\_\_\_

NAME \_\_\_\_\_

COMPANY \_\_\_\_\_

DIVISION \_\_\_\_\_

STREET \_\_\_\_\_

CITY \_\_\_\_\_ STATE \_\_\_\_\_ ZIP \_\_\_\_\_

COUNTRY \_\_\_\_\_

TELEPHONE \_\_\_\_\_ FAX \_\_\_\_\_

My application is \_\_\_\_\_

Is this your first purchase from Dynisco? YES \_\_\_\_\_ NO \_\_\_\_\_

How did you first hear of Dynisco? ADVERTISING \_\_\_\_\_ REP \_\_\_\_\_

PREVIOUS USE \_\_\_\_\_ COLLEAGUE \_\_\_\_\_ DIRECTORY \_\_\_\_\_

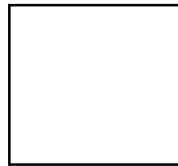
I need further product information on \_\_\_\_\_

I need application help on \_\_\_\_\_

Please send complete catalog \_\_\_\_\_

Tel.: 508-541-9400 Fax: 508-541-9436 E-mail: [www.dynisco.com](http://www.dynisco.com)

**PLEASE FOLD AND STAPLE OR TAPE**



DYNISCO INSTRUMENTS  
38 FORGE PARKWAY  
FRANKLIN, MA 02038

ATTN: MARKETING DEPT.

# NOTES

# Melt Pressure Transducer Quick Start Instructions

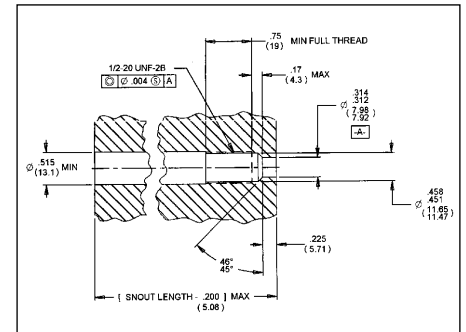
## Important:

- Do not remove protective cap until ready to install.
- Prior to installation, verify correct machining of mounting hole.
- When re-installing, make sure mounting hole is clear of frozen plastic.
- Transducer should be removed when at operating temperature (no pressure in system).

## 1. Prepare the Mounting hole.

The mounting hole outline drawing for standard 1/2-20 UNF threaded versions is given below. Careful attention should be paid to correctly machining the mounting hole.

A set of mounting hole machining tools (Dynisco Part # 200925) is included with all the necessary drills, taps and reamers (only in Starter Dynipak). When machining the hole, pay careful attention to the concentricity between the threads and the .312/.314 diameter. Since the pressure seal is on the 45° seating surface, this surface should be examined for good finish, free from burrs, etc.



## 2. Transducer Installation

To prevent galling, the transducer threads should be lubricated with the high-temperature anti-seize compound included.

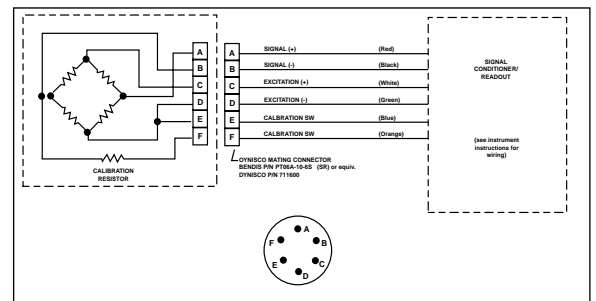
In a properly machined mounting hole, an adequate seal should be obtained with 100 inch-pounds of mounting torque. The maximum recommended installation torque is 500 inch-pounds.

When reinstalling the transducer, the hole must be free of frozen plastic. It is recommended that the barrel/manifold be at operating temperature. A mounting hole cleaning tool kit is available (Dynisco Part # 200100) to aid in removing material from .312 diameter, 45° seat and the threads. A gauge plug to check the hole is included with this kit.

## 3. Wiring

These transducers are connected to external signal conditioning/readout instrumentation with a six-wire shielded cable assembly. Dynisco six-wire shielded cable assembly is recommended. The cable should not be run in the same conduit as the AC power cables. The cable shield should be grounded at one end only.

Highest shunt calibration accuracy (R-CAL) is obtained with recommended six-wire cable and the transducer internal calibration resistor. Use of four-wire systems with remote external calibration is not recommended.



For more detailed information, see the manual shipped with the transducer.



*P-N 974097 Rev. B  
10/00  
ECO # 23134*

**DYNISCO INSTRUMENTS**

**38 Forge Parkway**

**Franklin, MA 02038**

**Tel.: 508-541-9400**

**Fax: 508-541-9436**